

INTEGRATED[®]
(Integrated Elastomers[®] USA)
 is an established OEM manufacturer of **Engineered Elastomeric Products** designed for use in Integrated API 16A Monogrammed Pressure Control Equipment. Our Elastomer products are additionally qualified in the "Aftermarket" as they are compatibility and interchangeability to "fit" in industry standard major manufacturers pressure control equipment. Our Elastomers will meet or exceed the performance requirements of the latest API 16A (Fatigue, Stripping, Packing Element Access and High & Low Temperature).

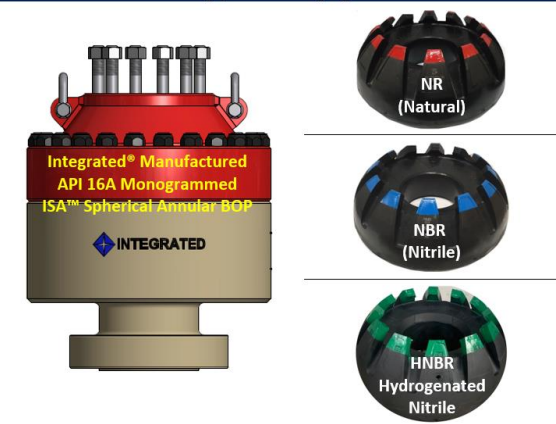

**INTEGRATED OEM SPHERICAL ANNULAR ISA[™] BOP
 MANUFACTURED ISA[™] ANNULAR PACKING ELEMENTS
 (Spherical Style)**



**INTEGRATED OEM ANNULAR IK[™] BOP
 MANUFACTURED ANNULAR IK[™] PACKING ELEMENTS
 (GK Style)**



**INTEGRATED PULSATION DAMPENERS
 MANUFACTURED DIAPHRAGMS (Bladders)
 Materials - NBR | HNBR | FKM | URETHANE
 Drilling (K Style) | Emsco Style (PD45, PD55 & PD55A) | Production (IP Style)**



INTEGRATED MANUFACTURED RAM BOPS

- IU[™] (Cameron U Style) • IWS[™] (NOV Shaffer LWS Style)
- IWP[™] (NOV Shaffer LWP Style) • IE[™] (WSI Style)



**INTEGRATED RAM BOP
 BLOCKS, FRONT PACKERS TOP SEALS,
 VBR, SBR, STRIPPER PRODUCTS**



INTEGRATED[®] is an API licensed Original Equipment Manufacturer (OEM) of Pressure and Flow Control Equipment for the Global Workover, Snubbing, Drilling, Rental and Production sectors of the Oil and Gas Industry

**INTEGRATED OEM MANUFACTURED – API MONOGRAMMED EQUIPMENT & PRODUCT
LICENSES AND CERTIFICATIONS**

API 6A	API 6A	API 6A - API 6C	API 16A	API 16A API 16AR	API 20E	ASME U CRN	API 16A - ISO AQ
WELLHEAD COMPONENTS	PRESSURE CONTROL VALVES	CHOKE & KILL MANIFOLDS	BLOWOUT PREVENTERS (BOP) RAM BLOCKS	REMANUFACTURING RECERTIFICATION SERVICE	BSL BOLTING	PULSATION DAMPENERS	ELASTOMERS OEM & SPARES
Tubing & Casing Spools	IFC™ Slab Gate Valves 1-13/16" to 4-1/2"	Drilling Choke Manifolds	7-1/16" IE™ Style: Single, Double & Triple Ram BOPs	BOPs: Annular & Ram All Major OEM Brands	Ram & Annular BOP Bolting	PPD (Production Pulsation Dampener) Sizes: 1, 2.5, 5, 10 & 20 gal units Pressure: up to 7,500 psi	BOP Annular Packing Elements (Materials: NR, NBR & HNBR)
Tubing & Casing Hangers	DrillFLO™ Slab Gate Valves (bi-directional & 3G) 2-1/16" to 7-1/16"	Kill Manifolds	9" IWP™ Style: Single & Double Ram BOPs	Choke & Kill Manifolds	Valve Bolting	DPD (Drilling Pulsation Dampener) Sizes: 10 & 20 gal units Pressure: up to 7,500 psi	BOP Ram Front Packers, Top Seals & Door Seals
Tree Caps	AceFLO™ Expanding Gate Valves (bi-directional & 3G) 2-1/16" to 7-1/16"	Frac Flow Back Manifolds	11" & 13-5/8" IWS™ Style: Single & Double Ram BOPs	API Valves (FC, FLS, Etc.)			BOP Annular & Ram Repair Carded Seal Kits
Tees & Crosses			7-1/16" through 13-5/8" IU™ Style: Single & Double Ram BOPs (Shear & Non-Shear)	Pulsation Dampeners			Pulsation Dampener Diaphragms (Bladders)
Companion Flanges			7-1/16" through 21-1/4" ISA™ Style: Spherical Annular BOPs				Pipe Wipers & Stripper Rubbers
PE Seals			7-1/16" through 13-5/8" IK™ Style: GK Annular BOP				Custom Manufacturing
			7-1/16" through 13-5/8" Ram Blocks (IE™, IWP™, I70™ & IU™)				

Integrated's API Certified – Licensed OEM plants provide state-of-the-art manufacturing of our Engineered-Designed Pressure Control Equipment and Elastomeric Products.



Integrated's Oracle - JD Edwards Enterprise Resource Planning (ERP) system integrates our global manufacturing, distribution facilities and service centers

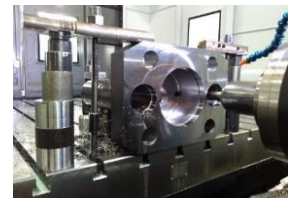
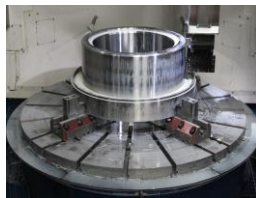

INTEGRATED ELASTOMER MANUFACTURING PLANT – USA

Integrated Elastomers® USA was established to manufacture and provide “In-house” engineered elastomeric products designed for Integrated OEM Pressure Control Industry Standard Equipment (API 6A | API 16A | API 20E | ASME U). Integrated Elastomers® USA provides a complete line of Oilfield Rubber Products. Our manufacturing division produces a variety of engineered rubber products for our pressure control equipment and for the aftermarket (Spare Parts). We take great pride in producing some of the largest and most precisely engineered Elastomeric parts available.



THE INTEGRATED ADVANTAGE

- All Elastomer products are designed, engineered and manufactured by Integrated Elastomer USA in coordination with Integrated Corporate OEM Pressure Control Equipment specifications
- OEM Elastomer Manufacturing specific to the oil & gas pressure control market
- Integrated manufactured aftermarket Premier Oilfield Products
- Proven track record with major drilling, snubbing and workover clients
- Large stock inventory or quick production turnaround to satisfy customer delivery needs
- Customer 24/7 support and access to purchased product MTRs or COCs through Integrated FTP (File Transfer Portal) site
- Wide variety of Elastomeric materials to satisfy customers job specific needs
- Client stocking programs and corporate pricing structures
- Professional customer focus from inquiry quotations, delivery to satisfaction follow-up

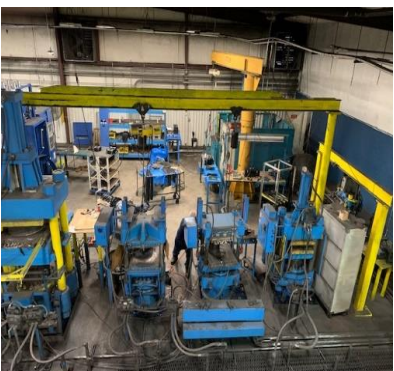

INDEX

1	GENERAL INFORMATION	Page No.
	➤ Integrated Manufactured API Monogrammed Pressure and Flow Control Equipment and Products	2
	➤ Integrated Elastomer Manufacturing Plant (USA) Integrated Elastomeric Introduction and “The Integrated Advantage”	3
	➤ Integrated Manufactured Equipment & Elastomer API 16A Validation BOP Strip Life testing Temperature Validation	7
	➤ Integrated Equipment and Elastomer Validation - Annular & Ram	7
	➤ Integrated OEM Manufacturing Capabilities	8
2	ANNULAR BOP PACKING ELEMENTS	
	➤ ISA™ Spherical Annular Packing Elements (NOV Shaffer Spherical Style)	9
	➤ IK™ Annular Packing Elements (Hydril GK Style)	9
3	RAM BOP FRONT PACKERS TOP SEALS MULTI RAMS VARIABLE BORE RAM (VBR) SHEAR BLIND RAM (SBR)	
	➤ 7-1/16” – 3/5k, IE™ Ram (WSI / T81 Style)	10
	➤ 7-1/16” – 5k, I61™ Ram (T61 (LWS Style)	11
	➤ 7-1/16” – 3/15k, IU™ Ram - Safety (U Style)	12
	➤ 7-1/16” – 3/15k, IU™ Ram – Stripper & Inserts (U Style)	13
	➤ 9” – 3/5k, IWPT™ Ram (LWP Style)	14
	➤ 11” – 3k, I70™ Ram (T70 - LWS Style)	15
	➤ 11” – 5k, I70™ Ram (T70 - LWS Style)	16
	➤ 11” – 3/10k IU™ Ram - Safety (U Style)	17
	➤ 13-5/8” – 5k, I70™ Ram (T70 - LWS Style)	18
	➤ 13-5/8” – 3/10k, IU™ Ram - Safety (U Style)	19
4	RAM BOP SEAL KITS	
	➤ 7-1/16” – 3/5k, IE™ Ram Seal Kit – Hydraulic (WSI / T81 Style)	20
	➤ 7-1/16” – 3/5k, T81 Ram Seal Kit - Hydraulic	20
	➤ 7-1/16” – 3/5k, T81 Ram Seal Kit - Manual	20
	➤ 7-1/16” – 3/5k, IE™ / T81 Ram Combo Seal Kit – Hydraulic (WSI / T81 Style)	20
	➤ 7-1/16” – 5k, Sentry Ram Seal Kit – Hydraulic (Sentry Style)	20
	➤ 7-1/16” – 5k, I61™ Ram Seal Kit – Hydraulic (T61 Style)	20
	➤ 7-1/16” – 3/15k, IU™ Ram Standard Bonnet Complete Seal Kit - Hydraulic (U Style)	21
	➤ 7-1/16” – 3/15k, IU™ Ram Standard Bonnet Soft Goods Seal Kit - Hydraulic (U Style)	21
	➤ 7-1/16” – 3/15k, IU™ Ram Standard Bonnet Hard Goods Seal Kit – Hydraulic (U Style)	21
	➤ 7-1/16” – 3/15k, IU™ Ram Large Bore Complete Seal Kit - Hydraulic (U Style)	21
	➤ 7-1/16” – 3/15k, IU™ Ram Large Bore Soft Goods Seal Kit - Hydraulic (U Style)	21
	➤ 7-1/16” – 3/15k, IU™ Ram Large Bore Hard Goods Seal Kit – Hydraulic (U Style)	21
	➤ 7-1/16” – 3/15k, IU™ Ram Tandem Booster Complete Seal Kit - Hydraulic (U Style)	21
	➤ 7-1/16” – 3/15k, IU™ Ram Tandem Booster Soft Goods Seal Kit - Hydraulic (U Style)	21
	➤ 7-1/16” – 3/15k, IU™ Ram Tandem Booster Hard Goods Seal Kit – Hydraulic (U Style)	21
	➤ 7-1/16” – 3/15k, IU™ Ram Mud Seal Kit – Hydraulic (U Style)	21
	➤ 9” – 3/5k, IWPT™ Ram Seal Kit - Hydraulic (LWP Style)	20
	➤ 11” – 3k, IWS™ Ram Complete Seal Kit - Hydraulic (LWS Style)	20
	➤ 11” – 3k, IWS™ Ram Soft Goods Seal Kit - Hydraulic (LWS Style)	20
	➤ 11” – 5k, IWS™ Ram Complete Seal Kit - Hydraulic (LWS Style)	20
	➤ 11” – 5k, IWS™ Ram Soft Goods Seal Kit - Hydraulic (LWS Style)	20
	➤ 11” – 3/10k, IU™ Ram Standard Bonnet Complete Seal Kit - Hydraulic (U Style)	21
	➤ 11” – 3/10k, IU™ Ram Standard Bonnet Soft Goods Seal Kit - Hydraulic (U Style)	21
	➤ 11” – 3/10k, IU™ Ram Standard Bonnet Hard Goods Seal Kit – Hydraulic (U Style)	21
	➤ 11” – 3/10k, IU™ Ram Large Bore Complete Seal Kit - Hydraulic (U Style)	21
	➤ 11” – 3/10k, IU™ Ram Large Bore Soft Goods Seal Kit - Hydraulic (U Style)	22
	➤ 11” – 3/10k, IU™ Ram Large Bore Hard Goods Seal Kit – Hydraulic (U Style)	21
	➤ 11” – 3/10k, IU™ Ram Tandem Booster Complete Seal Kit - Hydraulic (U Style)	21
	➤ 11” – 3/10k, IU™ Ram Tandem Booster Soft Goods Seal Kit - Hydraulic (U Style)	21
	➤ 11” – 3/10k, IU™ Ram Tandem Booster Hard Goods Seal Kit – Hydraulic (U Style)	21

INDEX

4	CONTINUE RAM BOP SEAL KITS	Page No.
	➤ 13-5/8" – 5k, IWS™ Ram Complete Seal Kit - Hydraulic (LWS Style)	20
	➤ 13-5/8" – 5k, IWS™ Ram Soft Goods Seal Kit - Hydraulic (LWS Style)	20
	➤ 13-5/8" – 3/10k, IUT™ Ram Standard Bonnet Complete Seal Kit - Hydraulic (U Style)	21
	➤ 13-5/8" – 3/10k, IUT™ Ram Standard Bonnet Soft Goods Seal Kit - Hydraulic (U Style)	21
	➤ 13-5/8" – 3/10k, IUT™ Ram Standard Bonnet Hard Goods Seal Kit – Hydraulic (U Style)	21
	➤ 13-5/8" – 3/10k, IUT™ Ram Large Bore Complete Seal Kit - Hydraulic (U Style)	21
	➤ 13-5/8" – 3/10k, IUT™ Ram Large Bore Soft Goods Seal Kit - Hydraulic (U Style)	21
	➤ 13-5/8" – 3/10k, IUT™ Ram Large Bore Hard Goods Seal Kit – Hydraulic (U Style)	21
	➤ 13-5/8" – 3/10k, IUT™ Ram Tandem Booster Complete Seal Kit - Hydraulic (U Style)	21
	➤ 13-5/8" – 3/10k, IUT™ Ram Tandem Booster Soft Goods Seal Kit - Hydraulic (U Style)	21
	➤ 13-5/8" – 3/10k, IUT™ Ram Tandem Booster Hard Goods Seal Kit – Hydraulic (U Style)	21
5	RAM BOP DOOR SEALS	
	➤ 7-1/16" – 3/5k, IE™ Ram Molded Door Seal (Fits T81, WSI and Sentry BOPs)	22
	➤ 7-1/16" – 3k, IWS™ Ram Door Seal (Fits T61 BOP)	22
	➤ 7-1/16" – 3/15k, IUT™ Ram Molded Door Seal (Fits U BOP)	22
	➤ 9" – 3/5k, IWPT™ Ram Door Seal (Fits LWP BOP)	22
	➤ 11" – 3k, IWS™ Ram Door Seal (Fits LWS BOP)	22
	➤ 11" – 5k, IWS™ Ram Door Seal (Fits LWS BOP)	22
	➤ 11" – 3/10k, IUT™ Ram Molded Door Seal (Fits U BOP)	22
	➤ 13-5/8" – 5k, IWS™ Ram Door Seal (Fits LWS BOP)	22
	➤ 13-5/8" – 3/10k, IUT™ Ram Molded Door Seal (Fits U BOP)	22
6	ANNULAR BOP SEAL KITS (Spherical and GK Styles)	
	➤ 7-1/16" – 3/5k, ISA™ Spherical Annular Complete Seal Kit (Fits Shaffer Spherical / T90 Styles)	23
	➤ 9" – 3k, ISA™ Spherical Annular Complete Seal Kit (Fits Shaffer Spherical / T90 Styles)	23
	➤ 11" – 3k, ISA™ Spherical Annular Complete Seal Kit (Fits Shaffer Spherical / T90 Styles)	23
	➤ 11" – 5k, ISA™ Spherical Annular Complete Seal Kit (Fits Shaffer Spherical / T90 Styles)	23
	➤ 13-5/8" – 3/5k, ISA™ Spherical Annular Complete Seal Kit (Fits Shaffer Spherical / T90 Styles)	23
	➤ 21-1/4" – 2k, ISA™ Spherical Annular Complete Seal Kit (Fits Shaffer Spherical / T90 Styles)	23
	➤ Spherical Wear Bands	23
	➤ 7-1/16" – 5k, IK™ Annular Complete Seal Kit (Fits GK / T84 Styles)	23
	➤ 11" – 5k, IK™ Annular Complete Seal Kit (Fits GK / T84 Styles)	23
	➤ 13-5/8" – 5k, IK™ Annular Complete Seal Kit (Fits GK / T84 Styles)	23
7	ANNULAR BOP SEAL LAYOUT	
	➤ Seal Breakdown	24
8	PULSATION DAMPENER DIAPHRAGMS (Bladders) & ASSESSORIES	
	➤ Production Pulsation Dampener Diaphragms (PPD): Sizes – 1, 2.5, 5, 10 & 20 Gal / NBR, HNBR, FKM & Urethane Materials	26
	➤ Drilling Pulsation Dampener Diaphragms (DPD): Sizes – 10 & 20 Gal / NBR, HNBR, FKM & Urethane Materials	26
	➤ Emsco Diaphragms: Sizes – PD 45, PD 55 & PD 55A / NBR, HNBR, FKM & Urethane Materials	26
	➤ Pulsation Dampener Parts: Charge Hoses, Charging Valves, Stabilizer Plates & Bottom Gaskets	27
9	DRILLING PIPE WIPERS	
	➤ Designs: Flats and Duals: Sizes – 9", 12", 14", 17", 22", 24" & 26" (referenced O.D) in Red and Black Colors	28
10	ELASTOMERIC INFORMATION	
	➤ Elastomer Material Description: NR, NBR, HNBR, XNBR, FKM, UHMW & Urethane	29
	➤ Elastomer Material Compatibility	30
	➤ Elastomer Recommended Operating Range	30
	➤ Storage and Age Control Guideline	31
	➤ Elastomer Packaging Coding System (as per latest API 16A Edition)	32

INDEX

11 INTEGRATED TERMS AND CONDITIONS

Page No.

➤ Terms & Conditions

33 & 34

12 INTEGRATED CORPORATE STATEMENTS

➤ Integrated Quality Policy

35

➤ Integrated Mission Statement

35

➤ Integrated Code of Conduct

36

➤ Integrated Health, Safety & Environment

36

13 INTEGRATED CONTACT INFORMATION

➤ Location Address | Phone Number | Email Address | Website

Back Cover 37

**INTEGRATED OEM MANUFACTURED
PRESSURE CONTROL EQUIPMENT AND ELASTOMER VALIDATION**

STRIPPING LIFE TESTING (As per API 16A Edition 4)

Integrated Vertical Strip Life System operates with an automatic control unit and integrated data acquisition system that captures cycle speed, force, gallon leakage, strip cycles and temperatures. The collected data predict precise strip life of ram packers and annular packing elements under API 16A & ISO Specification 13533 specified test conditions and parameters.

**INTEGRATED
ANNULAR BOP
STRIP LIFE
TEST FIXTURE**



**INTEGRATED
RAM BOP
STRIP LIFE
TEST FIXTURE**



**Temperature and Pressure Testing Chamber
(In accordance with Latest Edition API 16A)**

The standard specifies requirements for performance, design, materials, testing, inspection, welding, marking, handling, storing, and shipping of Drill-through equipment used for drilling for oil and gas. This standard defines service conditions in terms of pressure, temperature, and wellbore fluids for which the pressure control equipment will be designed. Equipment & Elastomer validation is conducted utilizing our pressurized temperature environmental chamber that has a capability **range of -40°F to 662°F** and the capacity of up to 21-1/4" size pressure control equipment to perform testing as per API 16A Edition 4 requirements.

As Per API 16A – Annular & Ram Equipment & Elastomer Validation Pressure Testing

**Annular BOP – Packing Element
CSO (Complete Shut OFF) Test**



**Annular BOP – Packing Element
Pipe Pressure Test**



**Annular BOP – Packing Element
Drift Pressure Test**



**Ram BOP – Front Packers, Top Seals
& Door Seal Function Pressure Test**



**High
Temperature**

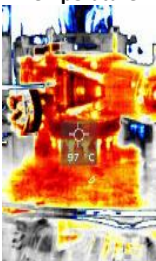

**Temperature & Pressure
Cryogenic Test Chamber**



**Low
Temperature**

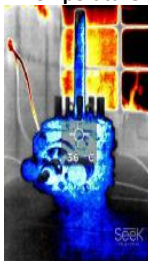

INTEGRATED OEM MANUFACTURING CAPABILITIES

ORIGINAL EQUIPMENT MANUFACTURER (OEM)	Yes
PRESSURE CONTROL EQUIPMENT DEIGN, ENGINEERING, MANUFACTURING & VALIDATION	Yes
OEM EQUIPMENT OFFERING:	
➤ Blowout Preventers (BOP) – API 16A Monogrammed	Yes
➤ Pressure Control Valves – API 6A Monogrammed	Yes
➤ Choke & Kill Manifolds – API 6A and API 16C Monogrammed	Yes
➤ Wellhead Components – API 6A Monogrammed	Yes
➤ Pulsation Dampeners (DPD & PPD) – ASME U, CRN & CE	Yes
➤ Accumulators (API 16D)	Yes
➤ Equipment Bolting – API 20E Monogrammed	Yes
OEM INTERNAL ELASTOMER MANUFACTURING	Yes
ELASTOMERS MANUFACTURED:	
➤ Spherical Annular Packing Element	Yes
➤ GK Annular Packing Element	Yes
➤ IE™ (WSI Style) Ram Top Seal, Front Packers & Door Seals	Yes
➤ IWP™ (LWP Style) Ram Top Seal, Front Packers & Door Seals	Yes
➤ I70™ (T70/LWS Style) Ram Top Seal-Front Packer Units & Door Seals	Yes
➤ IU™ (U Style) Ram Top Seal, Front Packers and Door Seals (SBR VBR)	Yes
➤ Seal Kits - Carded (For the above Style BOPs)	Yes
➤ Pulsation Dampener Diaphragms (Bladders) – K Style, IP Style, PD 45 & 55	Yes
➤ Drilling Pipe Wipers	Yes
INTEGRATED MANUFACTURING LICENSES AND OPERATIONAL CERTIFICATIONS - API 6A API 16A API 20E ASME U DNV Q1 ISO	Yes
WORLDWIDE PRODUCT DISTRIBUTION	Yes
FORUS ON SURFACE BUSINESS (Land and Above Water)	Yes
BETTER PRICING FOR CONTRACT CUSTOMERS	Yes
OEM QUALITY	Yes
SPARE PARTS FOR ALL MAJOR BRANDS	Yes
GLOBAL REPAIR & REMANUFACTURING (Recertification) – Integrated ARLF SSP	All Brands
➤ Can meet or exceed API 16AR – RSL2 and RSL3 requirements including Elastomers • OEM Remanufacturing of Integrated Equipment and CEM for all other major brands within our size & pressure	Yes

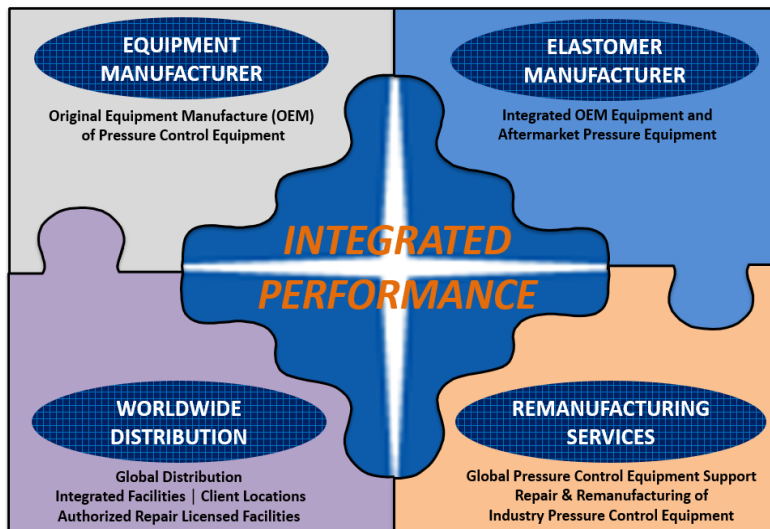

**INTEGRATED OEM MANUFACTURED
ANNULAR BOP PACKING ELEMENTS**

ISA™ SPHERICAL ANNULAR PACKING ELEMENTS



NR
(Natural)



NBR
(Nitrile)



HNBR
(Hydrogenated Nitrile)

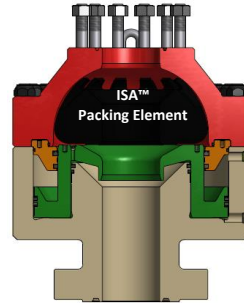

Integrated Manufactured
Monogrammed Spherical
Annular ISA™ BOP

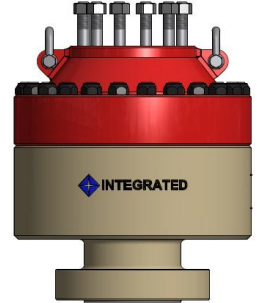

Packing Element Size	Pressure Rating	Element Material	Product Code	Weight Per Unit
7-1/16" (180 mm)	3k 5k	NR (Natural Rubber) – Snubbing	82-221-735-01	125 lbs 57 kg
		NBR (Nitrile Buna-N Rubber)	82-221-735-02	
		HNBR (Hydrogenated Nitrile)	82-221-735-03	
9" (229 mm)	3k 5k	NR (Natural Rubber)	82-221-903-01	260 lbs 118 kg
		NBR (Nitrile Buna-N Rubber)	82-221-903-02	
11" (279 mm)	3k	NR (Natural Rubber)	82-221-113-01	360 lbs 163 kg
		NBR (Nitrile Buna-N Rubber)	82-221-113-02	
11" (279 mm)	5k	NR (Natural Rubber)	82-221-115-01	463 lbs 210 kg
		NBR (Nitrile Buna-N Rubber)	82-221-115-02	
		HNBR (Hydrogenated Nitrile)	82-221-115-03	
13-5/8" (346 mm)	3k 5k	NR (Natural Rubber)	82-221-135-01	649 lbs 294 kg
		NBR (Nitrile Buna-N Rubber)	82-221-135-02	
		HNBR (Hydrogenated Nitrile)	82-221-135-03	
21-1/4" (540 mm)	2k	NR (Natural Rubber)	82-221-212-01	945 lbs 429 kg
		NBR (Nitrile Buna-N Rubber)	82-221-212-02	

IK™ (GK Style) ANNULAR PACKING ELEMENTS



NITRILE (NBR)



NATURAL (NR)

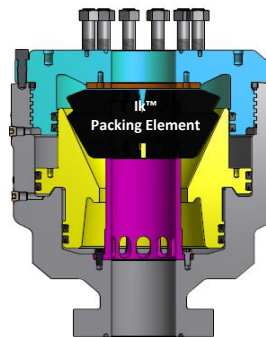

Integrated Manufactured
Monogrammed Annular (GK Style)
IK™ BOP



Packing Element Size	Pressure Rating	Element Material	Product Code	Weight Per Unit
7-1/16" (180 mm)	3k Called the "Shorty"	NR (Natural Rubber)	82-220-073-01	Qualified Outsource
		NBR (Nitrile Buna-N Rubber)	82-220-073-02	
7-1/16" (180 mm)	5k	NR (Natural Rubber)	82-220-075-01	120 lbs 54 kg
		NBR (Nitrile Buna-N Rubber)	82-220-075-02	
11" (279 mm)	3k	NR (Natural Rubber)	82-220-113-01	Qualified Outsource
		NBR (Nitrile Buna-N Rubber)	82-220-113-02	
11" (279 mm)	5k	NR (Natural Rubber)	82-220-115-01	367 lbs 166 kg
		NBR (Nitrile Buna-N Rubber)	82-220-115-02	
13-5/8" (346 mm)	3k	NR (Natural Rubber)	82-220-133-01	Qualified Outsource
		NBR (Nitrile Buna-N Rubber)	82-220-133-01	
13-5/8" (346 mm)	5k	NR (Natural Rubber)	82-220-135-01	458 lbs 208 kg
		NBR (Nitrile Buna-N Rubber)	82-220-135-02	

INTEGRATED OEM MANUFACTURED

RAM BOP FRONT PACKERS AND TOP SEALS

7-1/16" – 3 | 5k IE™ (WSI Style) FRONT PACKERS & TOP SEALS

TOP SEAL OPTIONS



FRONT PACKER OPTIONS (Blind & Pipe)

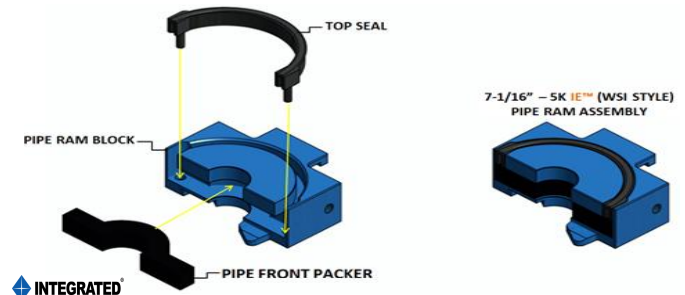
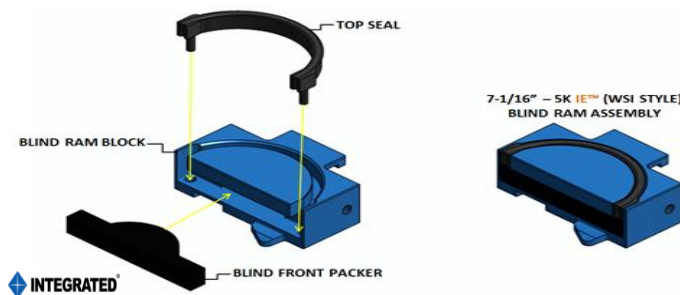
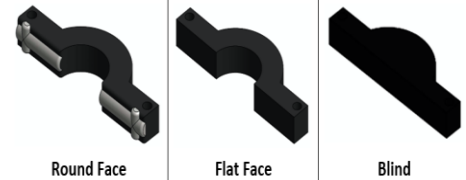

IE™ BLIND RAM ASSEMBLY

IE™ PIPE RAM ASSEMBLY

Integrated Manufactured (OEM) API 16A Monogrammed Ram Blocks Available Upon Request

TOP SEALS:

Description	Design	Size	Pressure Rating	Material	Product Code	Weight Per Unit
Top Seal	Mid Crown Round Face	CSO Thru 5-1/2"	3 5k	XNBR	70-101-000-R	0.40 lbs 0.18 kg
Top Seal	Mid Crown Flat Face	CSO Thru 5-1/2"	3 5k	XNBR	70-101-000-F	0.40 lbs 0.18 kg
Top Seal	Low Crown Flat Face	CSO Thru 5-1/2"	3 5k	XNBR	70-101-000	0.40 lbs 0.18 kg

FRONT PACKERS:

Description	Design	Size	Pressure Rating	Material	Product Code	Weight Per Unit
Front Packer	Round Face	CSO	3 5k	XNBR	70-0705-00289	1.80 lbs 0.54 kg
Front Packer	Flat Face	CSO	3 5k	XNBR	70-101-001-1	1.80 lbs 0.54 kg
Front Packer	Round Face	1.66"	3 5k	XNBR	-	1.40 lbs 0.64 kg
Front Packer	Flat Face	1.66"	3 5k	XNBR	70-101-002-15	1.40 lbs 0.64 kg
Front Packer	Round Face	1.90"	3 5k	XNBR	-	1.60 lbs 0.73 kg
Front Packer	Flat Face	1.90"	3 5k	XNBR	70-101-002-1	1.60 lbs 0.73 kg
Front Packer	Round Face	2-1/16"	3 5k	XNBR	-	1.50 lbs 0.68 kg
Front Packer	Flat Face	2-1/16"	3 5k	XNBR	70-101-002-11	1.50 lbs 0.68 kg
Front Packer	Round Face	2-3/8"	3 5k	XNBR	70-0705-00290	1.40 lbs 0.64 kg
Front Packer	Flat Face	2-3/8"	3 5k	XNBR	70-101-002-2	1.40 lbs 0.64 kg
Front Packer	Round Face	2-7/8"	3 5k	XNBR	70-0705-00293	1.40 lbs 0.64 kg
Front Packer	Flat Face	2-7/8"	3 5k	XNBR	70-101-002-3	1.40 lbs 0.64 kg
Front Packer	Round Face	3-1/2"	3 5k	XNBR	70-0705-00294	1.00 lbs 0.45 kg
Front Packer	Flat Face	3-1/2"	3 5k	XNBR	70-101-002-5	1.00 lbs 0.45 kg
Front Packer	Round Face	4"	3 5k	XNBR	-	1.20 lbs 0.54 kg
Front Packer	Flat Face	4"	3 5k	XNBR	70-101-002-6	1.20 lbs 0.54 kg
Front Packer	Round Face	4-1/2"	3 5k	XNBR	-	1.20 lbs 0.54 kg
Front Packer	Flat Face	4-1/2"	3 5k	XNBR	70-101-002-7	1.20 lbs 0.54 kg
Front Packer	Round Face	5"	3 5k	XNBR	-	0.80 lbs 0.36 kg
Front Packer	Flat Face	5"	3 5k	XNBR	70-101-002-8	0.80 lbs 0.36 kg
Front Packer	Round Face	5-1/2"	3 5k	XNBR	-	0.80 lbs 0.36 kg
Front Packer	Flat Face	5-1/2"	3 5k	XNBR	70-101-002-13	0.80 lbs 0.36 kg

I-FLEX™ PACKERS (IE™ / WSI / T81 Style):

Description	Size	Pressure Rating	Material	Product Code	Weight Per Unit
I-FLEX™ Packer	2-3/8" to 2-7/8"	3 5k	XNBR	70-0705-00211	1.80 lbs 0.54 kg

INTEGRATED OEM MANUFACTURED

RAM BOP FRONT PACKER – TOP SEAL UNITS

7-1/16" – 5k I61™ (LWS Style) FRONT PACKER – TOP SEAL UNIT

BLIND FRONT PACKER – TOP SEAL UNIT



PIPE FRONT PACKER – TOP SEAL UNIT

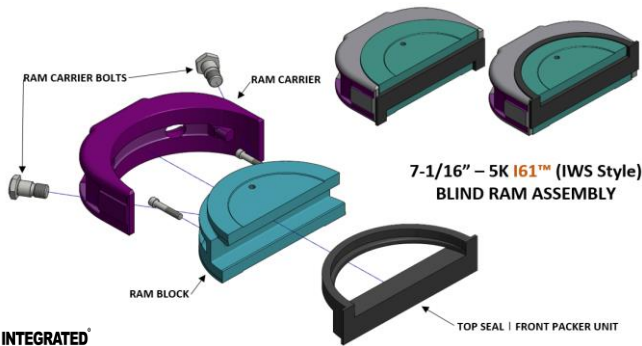

**7-1/16" – 5K I61™ (IWS Style)
BLIND RAM ASSEMBLY**

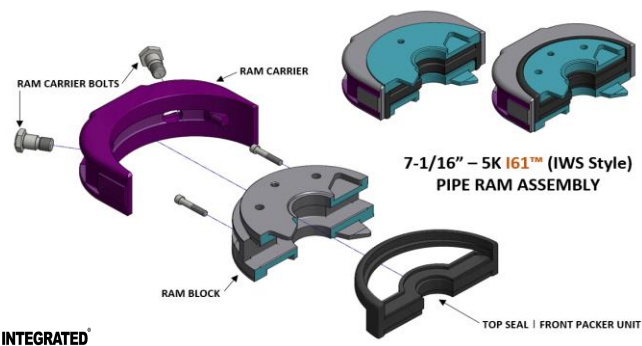

**7-1/16" – 5K I61™ (IWS Style)
PIPE RAM ASSEMBLY**



I61™ BLIND RAM ASSEMBLY

I61™ PIPE RAM ASSEMBLY

Integrated Manufactured (OEM) API 16A Monogrammed Ram Blocks Available Upon Request

FRONT PACKER – TOP SEAL UNITS:

Description	Size	Pressure Rating	Material	Product Code	Weight Per Unit
Front Packer – Top Seal Unit	CSO	5k	NBR	70-135857	4.80 lbs 2.18 kg
Front Packer – Top Seal Unit	1.660"	5k	NBR	70-135847	5.00 lbs 2.27 kg
Front Packer – Top Seal Unit	2-1/16"	5k	NBR	70-142644	4.80 lbs 2.18 kg
Front Packer – Top Seal Unit	2-3/8"	5k	NBR	70-135858	4.40 lbs 2.00 kg
Front Packer – Top Seal Unit	2-7/8"	5k	NBR	70-135859	4.20 lbs 1.91 kg
Front Packer – Top Seal Unit	3-1/2"	5k	NBR	70-135860	4.20 lbs 1.91 kg
Front Packer – Top Seal Unit	4"	5k	NBR	70-135861	4.00 lbs 1.81 kg
Front Packer – Top Seal Unit	4-1/2"	5k	NBR	70-135862	3.80 lbs 1.72 kg
Front Packer – Top Seal Unit	5"	5k	NBR	70-142725	3.80 lbs 1.72 kg
Front Packer – Top Seal Unit	5-1/2"	5k	NBR	70-116116	3.40 lbs 1.54 kg

MULTI RAM – TOP SEALS AND FRONT PACKERS:

Description	Size	Pressure Rating	Material	Product Code	Weight Per Unit
Multi Ram – Top Seal	2-3/8" to 3-1/2"	5k	NBR	70-122451	1.40 lbs 0.64 kg
Multi Ram – Front Packer	2-3/8" to 3-1/2"	5k	NBR	70-122899	6.20 lbs 2.81 kg

INTEGRATED OEM MANUFACTURED

RAM BOP FRONT PACKERS AND TOP SEALS

7-1/16" – 3 | 15k IU™ (U Style) SAFETY FRONT PACKER & TOP SEALS

TOP SEAL



SAFETY FRONT PACKER (Blind | Pipe | VBR | SBR)

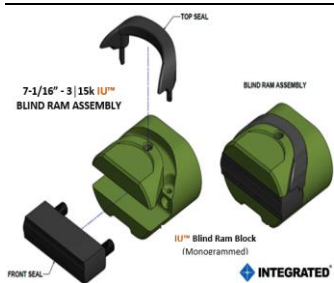

IU™ BLIND RAM ASSEMBLY

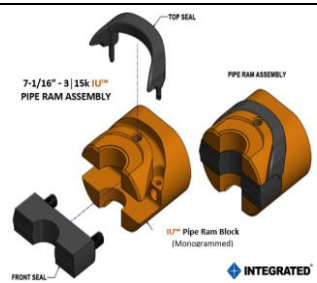

IU™ PIPE RAM ASSEMBLY



IU™ VARIABLE BORE ASSEMBLY

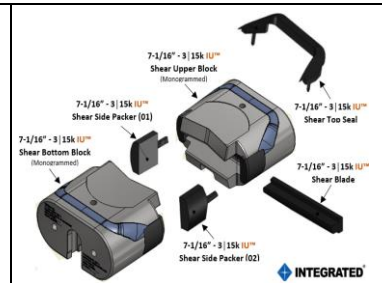

IU™ SHEAR BLIND ASSEMBLY

Integrated Manufactured (OEM) API 16A Monogrammed Ram Blocks Available Upon Request

TOP SEALS:

Description	Size	Pressure Rating	Material	Product Code	Weight Per Unit
Top Seal	CSO Thru 5-1/2"	3 5 10 15k	XNBR	70-0703-00029	0.80 lbs 0.36 kg

SAFETY FRONT PACKERS: "I-RAM"

Description	Size	Pressure Rating	Material	Product Code	Weight Per Unit
Front Packer	CSO	3 15k	XNBR	70-0703-00009	7.00 lbs 3.16 kg
Front Packer	2-3/8"	3 15k	XNBR	70-0703-00010	6.40 lbs 2.90 kg
Front Packer	2-7/8"	3 15k	XNBR	70-0703-00011	6.20 lbs 2.81 kg
Front Packer	3-1/2"	3 15k	XNBR	70-0703-00012	5.80 lbs 2.63 kg
Front Packer	4"	3 15k	XNBR	70-0703-00013	5.60 lbs 2.54 kg
Front Packer	4-1/2"	3 15k	XNBR	70-0703-00014	5.00 lbs 2.27 kg
Front Packer	5"	3 15k	XNBR	70-0703-00015	4.80 lbs 2.18 kg
Front Packer	5-1/2"	3 15k	XNBR	70-0703-00016	4.60 lbs 2.09 kg

VARIABLE BORE RAM (VBR): TOP SEALS AND FRONT PACKERS:

Description	Size	Pressure Rating	Material	Product Code	Weight Per Unit
VBR – Top Seal	2-3/8" to 3-1/2" 2-7/8" to 4"	3 15k	XNBR	70-0703-00029-V	0.80 lbs 0.36 kg
VBR – Front Packer	2-3/8" to 3-1/2"	3 15k	NBR	95-0710000-V-03	8.40 lbs 3.81 kg
VBR – Front Packer	2-7/8" to 4"	3 15k	NBR	95-0710000-V-04	8.10 lbs 3.67 kg

SHEAR BLIND RAM (SBR): TOP SEALS | BLADE PACKER | SIDE PARKERS:

Description	Size	Pressure Rating	Material	Product Code	Weight Per Unit
SBR – Top Seal	7-1/16"	3 15k	XNBR	70-0703-00029	0.80 lbs 0.36 kg
SBR – Blade Packer	7-1/16"	3 15k	XNBR	95-07100023-BP	4.60 lbs 2.90 kg
SBR – Side Packer 01	7-1/16"	3 15k	XNBR	95-07100023-SP01	1.00 lbs 0.45 kg
SBR – Side Packer 02	7-1/16"	3 15k	XNBR	95-07100023-SP02	1.00 lbs 0.45 kg

The 7-1/16" – 3/15k IU™ Top Seal is the same for the CSO, all Pipe Sizes and SBR. The Top Seal for the VBR is different

INTEGRATED OEM MANUFACTURED

SAFETY & STRIPPER FRONT PACKERS AND INSERTS

7-1/16" – 3 | 15k IU™ (U Style) SNUBBING PRODUCTS



Description	Size	Pressure Rating	Material	Product Code	Weight Per Unit
IU™ Top Seal	CSO Thru 5-1/2"	3 5 10 15k	XNBR	70-0703-00029	0.80 lbs 0.36 kg

IU™ TOP SEAL:

IU™ STRIPPER FRONT PACKER: Standard Style (Screw Securing Device)

Description	Special Feature	Size	Pressure Rating	Material	Product Code	Weight Per Unit
Stripper Front Packer	Standard Style – Insert secured with screws	2-3/8"	3 15k	XNBR	70-0703-00017	6.00 lbs 2.72 kg
Stripper Front Packer	Standard Style – Insert secured with screws	2-7/8"	3 15k	XNBR	70-0703-00018	5.80 lbs 2.63 kg
Stripper Front Packer	Standard Style – Insert secured with screws	3-1/2"	3 15k	XNBR	70-0703-00019	5.40 lbs 2.45 kg

IU™ STRIPPER FRONT PACKER: Engineered Designed Insert Securing System Style (Insert Pin)

Description	Special Feature	Size	Pressure Rating	Material	Product Code	Weight Per Unit
* Stripper Front Packer	Insert Securing Device System Stripping Packer	2-3/8"	3 15k	XNBR	70-0703-00017-I	6.00 lbs 2.72 kg
* Stripper Front Packer	Insert Securing Device System Stripping Packer	2-7/8"	3 15k	XNBR	70-0703-00018-I	5.80 lbs 2.63 kg
* Stripper Front Packer	Insert Securing Device System Stripping Packer	3-1/2"	3 15k	XNBR	70-0703-00019-I	5.40 lbs 2.45 kg

IU™ STRIPPER INSERTS:

Description	Size	Pressure Rating	Material	Product Code	Weight Per Unit
Stripper Insert (ST)	2-3/8"	3 15k	UHMW (Standard Temperature)	70-0703-00023	7.00 lbs 3.56 kg
Stripper Insert (HT)	2-3/8"	3 15k	TEFLON-M (High Temperature)	70-0703-00023-HT	6.40 lbs 2.90 kg
Stripper Insert (ST)	2-7/8"	3 15k	UHMW (Standard Temperature)	70-0703-00024	6.20 lbs 2.81 kg
Stripper Insert (HT)	2-7/8"	3 15k	TEFLON-M (High Temperature)	70-0703-00024-HT	7.00 lbs 3.56 kg
Stripper Insert (ST)	3-1/2"	3 15k	UHMW (Standard Temperature)	70-0703-00025	6.40 lbs 2.90 kg
Stripper Insert (HT)	3-1/2"	3 15k	TEFLON-M (High Temperature)	70-0703-00025-HT	6.20 lbs 2.81 kg

The Integrated Insert Packer for stripper application in snubbing services is designed with replaceable, wear resistant, non-rotating insert. The insert is manufactured from an ultra-high molecular weight polyethylene (UHMW).

**Integrated has designed and engineered a new 7-1/16" – 3/15k IU™ Stripper Front Packer Insert Securing System that is manufactured as an integral component within the Stripper Packer. The securing system eliminates the need for screws or the risk of losing the insert.*



INTEGRATED OEM MANUFACTURED

RAM BOP FRONT PACKERS AND TOP SEALS

**9" – 3 | 5k IWP™ FRONT PACKER AND TOP SEAL
(LWP Sentinel II Style | T81 - 9" Style)**

TOP SEAL



FRONT PACKER (Blind & Pipe)

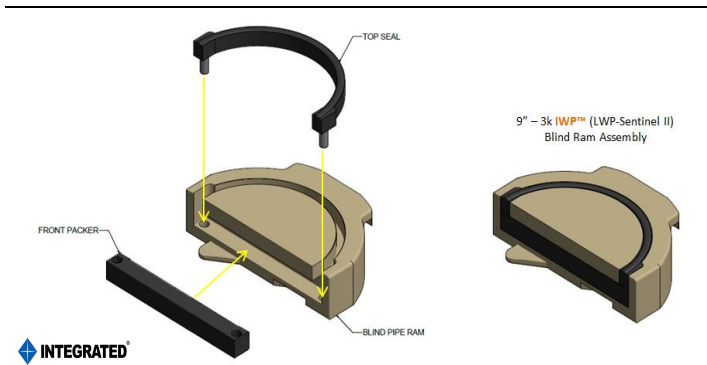
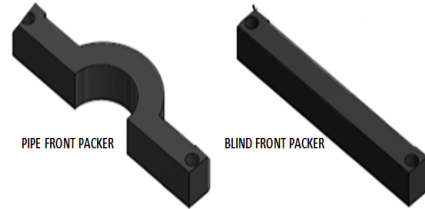

IWP™ BLIND RAM ASSEMBLY

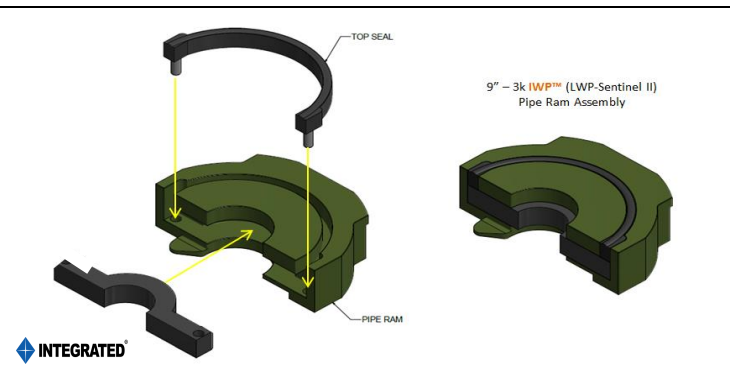

IWP™ PIPE RAM ASSEMBLY

Integrated Manufactured (OEM) API 16A Monogrammed Ram Blocks Available Upon Request

TOP SEAL:

Description	Size	Pressure Rating	Material	Product Code	Weight Per Unit
Top Seal (Round Face)	Fits CSO Thru 5-1/2"	3 5k	XNBR	70-102-001-2	0.60 lbs 0.27 kg
Top Seal (Flat Face)	Fits CSO Thru 5-1/2"	3 5k	XNBR	70-102-000	0.60 lbs 0.27 kg

FRONT PACKERS:

Description	Size	Pressure Rating	Material	Product Code	Weight Per Unit
Front Packer (Round Back)	CSO	3 5k	XNBR	70-102-001-1	2.00 lbs 0.91 kg
Front Packer (Flat Back)	CSO	3 5k	XNBR	70-102-001	2.00 lbs 0.91 kg
Front Packer	2-3/8"	3 5k	XNBR	70-102-002-2	2.40 lbs 1.09 kg
Front Packer	2-7/8"	3 5k	XNBR	70-102-002-3	2.40 lbs 1.09 kg
Front Packer	3-1/2"	3 5k	XNBR	70-102-002-5	2.00 lbs 0.91 kg
Front Packer	4"	3 5k	XNBR	70-102-002-6	3.00 lbs 1.36 kg
Front Packer	4-1/2"	3 5k	XNBR	70-102-002-7	2.80 lbs 1.27 kg
Front Packer	5"	3 5k	XNBR	70-102-002-9	2.40 lbs 1.09 kg
Front Packer	5-1/2"	3 5k	XNBR	70-102-002-15	2.00 lbs 0.91 kg

MULTI RAM OR VBR – TOP SEALS AND FRONT PACKERS:

Description	Size	Pressure Rating	Material	Product Code	Weight Per Unit
-------------	------	-----------------	----------	--------------	-----------------

No Multi Ram or VBR offered for 9" – 3/5k IWP™

INTEGRATED OEM MANUFACTURED

RAM BOP FRONT PACKER – TOP SEAL UNITS

11" – 3k I70™ (T70 Style) FRONT PACKER – TOP SEAL UNIT

BLIND FRONT PACKER – TOP SEAL UNIT



PIPE FRONT PACKER – TOP SEAL UNIT

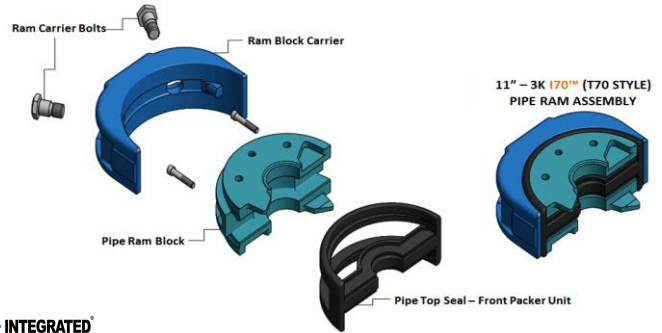
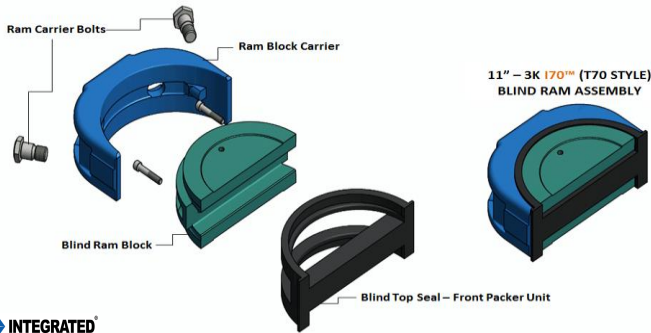

I70™ BLIND RAM ASSEMBLY

I70™ PIPE RAM ASSEMBLY

Integrated Manufactured (OEM) API 16A Monogrammed Ram Blocks Available Upon Request

FRONT PACKER – TOP SEAL UNITS:

Description	Size	Pressure Rating	Product Code NBR Material	Product Code XNBR Material	Product Code HNBR Material	Weight Per Unit
Front Packer – Top Seal Unit	CSO	3k	70-401-711	70-401-711-XBR	70-401-711-HSN	6.40 lbs 2.90 kg
Front Packer – Top Seal Unit	2-3/8"	3k	70-401-711-1	70-401-711-1-XBR	70-401-711-1-HSN	6.80 lbs 3.08 kg
Front Packer – Top Seal Unit	2-7/8"	3k	70-401-711-2	70-401-711-2-XBR	70-401-711-2-HSN	6.80 lbs 3.08 kg
Front Packer – Top Seal Unit	3-1/2"	3k	70-401-711-4	70-401-711-4-XBR	70-401-711-4-HSN	6.60 lbs 2.99 kg
Front Packer – Top Seal Unit	4"	3k	70-401-711-5	70-401-711-5-XBR	70-401-711-5-HSN	7.00 lbs 3.18 kg
Front Packer – Top Seal Unit	4-1/2"	3k	70-401-711-6	70-401-711-6-XBR	70-401-711-6-HSN	7.00 lbs 3.18 kg
Front Packer – Top Seal Unit	5"	3k	70-401-711-7	70-401-711-7-XBR	70-401-711-7-HSN	6.80 lbs 3.08 kg
Front Packer – Top Seal Unit	5-1/2"	3k	70-401-711-8	70-401-711-8-XBR	70-401-711-8-HSN	6.80 lbs 3.08 kg
Front Packer – Top Seal Unit	6-5/8"	3k	70-401-711-9	70-401-711-9-XBR	70-401-711-9-HSN	6.60 lbs 2.99 kg
Front Packer – Top Seal Unit	7"	3k	70-401-711-10	70-401-711-10-XBR	70-401-711-10-HSN	6.40 lbs 2.90 kg
Front Packer – Top Seal Unit	7-5/8"	3k	70-401-711-11	70-401-711-11-XBR	70-401-711-11-HSN	6.40 lbs 2.90 kg

MULTI RAM – TOP SEALS AND FRONT PACKERS:

Description	Size	Pressure Rating	Material	Product Code	Weight Per Unit
-------------	------	-----------------	----------	--------------	-----------------

No Multi Ram offered for 11" – 3k I70™

INTEGRATED OEM MANUFACTURED

RAM BOP FRONT PACKER – TOP SEAL UNITS

11" – 5k I70™ (T70 Style) FRONT PACKER – TOP SEAL UNIT

BLIND FRONT PACKER – TOP SEAL UNIT



PIPE FRONT PACKER – TOP SEAL UNIT

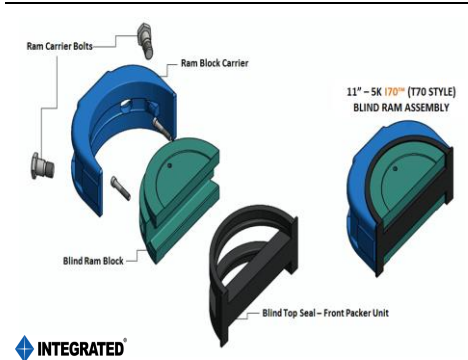

I70™ BLIND RAM ASSEMBLY

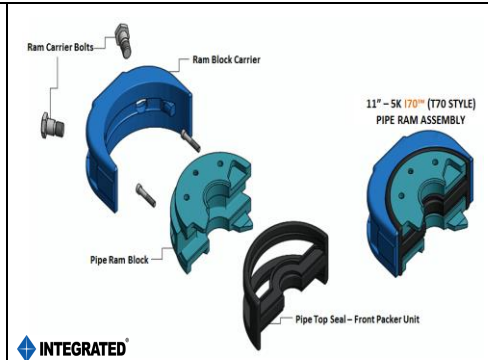

I70™ PIPE RAM ASSEMBLY

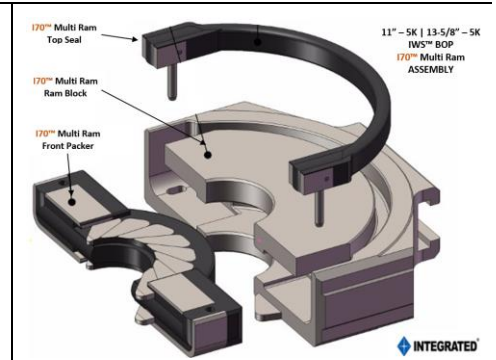

I70™ MULTI RAM ASSEMBLY

Integrated Manufactured (OEM) API 16A Monogrammed Ram Blocks Available Upon Request

FRONT PACKER – TOP SEAL UNITS:

Description	Size	Pressure Rating	Product Code NBR Material	Product Code XNBR Material	Product Code HNBR Material	Weight Per Unit
Front Packer – Top Seal Unit	CSO	5k	70-401-701	70-401-701-XBR	70-401-701-HSN	7.20 lbs 3.27 kg
Front Packer – Top Seal Unit	2-3/8"	5k	70-401-701-1	70-401-701-1-XBR	70-401-701-1-HSN	7.20 lbs 3.27 kg
Front Packer – Top Seal Unit	2-7/8"	5k	70-401-701-2	70-401-701-2-XBR	70-401-701-2-HSN	7.20 lbs 3.27 kg
Front Packer – Top Seal Unit	3-1/2"	5k	70-401-701-4	70-401-701-4-XBR	70-401-701-4-HSN	7.00 lbs 3.18 kg
Front Packer – Top Seal Unit	4"	5k	70-401-701-5	70-401-701-5-XBR	70-401-701-5-HSN	7.60 lbs 3.45 kg
Front Packer – Top Seal Unit	4-1/2"	5k	70-401-701-6	70-401-701-6-XBR	70-401-701-6-HSN	7.60 lbs 3.45 kg
Front Packer – Top Seal Unit	5"	5k	70-401-701-7	70-401-701-7-XBR	70-401-701-7-HSN	7.40 lbs 3.36 kg
Front Packer – Top Seal Unit	5-1/2"	5k	70-401-701-8	70-401-701-8-XBR	70-401-701-8-HSN	7.40 lbs 3.36 kg
Front Packer – Top Seal Unit	6-5/8"	5k	70-401-701-9	70-401-701-9-XBR	70-401-701-9-HSN	7.20 lbs 3.27 kg
Front Packer – Top Seal Unit	7"	5k	70-401-701-10	70-401-701-10-XBR	70-401-701-10-HSN	7.00 lbs 3.18 kg
Front Packer – Top Seal Unit	7-5/8"	5k	70-401-701-11	70-401-701-11-XBR	70-401-701-11-HSN	7.00 lbs 3.18 kg

MULTI RAM – TOP SEALS AND FRONT PACKERS:

Description	Size	Pressure Rating	Material	Product Code	Weight Per Unit
Multi Ram – Top Seal	2-7/8" to 5"	5K	NBR	70-401-701-V1	
Multi Ram – Top Seal	3-1/2" to 5-1/2"	5K	NBR	70-401-701-V1	
Multi Ram – Front Packer	2-7/8" to 5"	5k	NBR	70-401-701-V	9.20 lbs 4.17 kg
Multi Ram – Front Packer	3-1/2" to 5-1/2"	5k	NBR	70-401-701-V3	1.00 lbs 0.45 kg

The 11" – 5k I70™ Multi Ram Top Seal is the same for the 2-7/8" to 5" and 3-1/2" to 5-1/2" Assemblies

INTEGRATED OEM MANUFACTURED

RAM BOP FRONT PACKERS AND TOP SEALS

11" – 3 | 10k IU™ (U Style) FRONT PACKER & TOP SEALS

TOP SEAL



FRONT PACKER (Blind | Pipe | VBR | SBR)



<p>IU™ BLIND RAM ASSEMBLY</p>	<p>IU™ PIPE RAM ASSEMBLY</p>	<p>IU™ VARIABLE BORE ASSEMBLY</p>	<p>IU™ SHEAR BLIND ASSEMBLY</p>
--------------------------------------	-------------------------------------	--	--

Integrated Manufactured (OEM) API 16A Monogrammed Ram Blocks Available Upon Request

TOP SEALS:

Description	Size	Pressure Rating	Material	Product Code	Weight Per Unit
TOP SEAL	CSO Thru 9-5/8"	3 10k	XNBR	95-111000	1.6 lbs 0.73 kg

FRONT PACKERS: "I-RAM"

Description	Size	Pressure Rating	Material	Product Code	Weight Per Unit
Front PACKER	CSO	310k	XNBR	95-111002	11.60 lbs 5.26 kg
Front PACKER	2-3/8"	310k	XNBR	95-111002-2	10.80 lbs 4.90 kg
Front PACKER	2-7/8"	3 10k	XNBR	95-111002-3	10.60 lbs 4.81 kg
Front PACKER	3-1/2"	3 10k	XNBR	95-111002-5	10.40 lbs 4.72 kg
Front PACKER	4"	3 10k	XNBR	95-111002-6	10.20 lbs 4.63 kg
Front PACKER	4-1/2"	3 10k	XNBR	95-111002-7	10.40 lbs 4.72 kg
Front PACKER	5"	3 10k	XNBR	95-111002-8	10.40 lbs 4.72 kg
Front PACKER	5-1/2"	3 10k	XNBR	95-111002-9	12.00 lbs 5.44 kg
Front PACKER	6-5/8"	3 10k	XNBR	95-111002-10	11.00 lbs 4.99 kg
Front PACKER	7"	3 10k	XNBR	95-111002-11	9.80 lbs 4.45 kg
Front PACKER	7-5/8"	3 10k	XNBR	95-111002-12	9.80 lbs 4.45 kg
Front PACKER	8-5/8"	3 10k	XNBR	95-111002-13	9.60 lbs 4.35 kg
Front PACKER	9-5/8"	3 10k	XNBR	95-111002-14	9.40 lbs 4.26 kg

VARIABLE BORE RAM (VBR): TOP SEALS AND FRONT PACKERS:

Description	Size	Pressure Rating	Material	Product Code	Weight Per Unit
VBR – Top Seal	2-7/8" to 5" 3-1/2" to 5-1/2"	3 10k	XNBR	95-111000	1.60 lbs 0.73 kg
VBR – Front Packer	2-7/8" to 5"	3 10k	NBR	95-1110000-V-03	27.00 lbs 12.3 kg
VBR – Front Packer	3-1/2" to 5-1/2"	3 10k	NBR	95-1110000-V-05	27.00 lbs 12.3 kg

SHEAR BLIND RAM (SBR): TOP SEALS | BLADE PACKER | SIDE PARKERS:

Description	Size	Pressure Rating	Material	Product Code	Weight Per Unit
SBR – Top Seal	11"	3 10k	XNBR	95-111000	1.60 lbs 0.73 kg
SBR – Blade Packer	11"	3 10k	XNBR	95-11100023-BP	3.00 lbs 1.36 kg
SBR – Side Packer 01	11"	3 10k	XNBR	95-11100023-SP-01	2.20 lbs 0.99 kg
SBR – Side Packer 02	11"	3 10k	XNBR	95-11100023-SP-02	2.20 lbs 0.99 kg

For 11" – 3/10k IU™, the Top Seal is the same for the CSO, all Pipe Sizes, VBR and SBR

INTEGRATED OEM MANUFACTURED

RAM BOP FRONT PACKER – TOP SEAL UNITS

13-5/8” – 5k I70™ (T70 Style) FRONT PACKER – TOP SEAL UNIT

BLIND FRONT PACKER – TOP SEAL UNIT



PIPE FRONT PACKER – TOP SEAL UNIT



<p>13-5/8” – 5k I70™ (T70 STYLE) BLIND RAM ASSEMBLY</p>	<p>13-5/8” – 5k I70™ (T70 STYLE) PIPE RAM ASSEMBLY</p>	<p>11” – 5k 13-5/8” – 5k IWS™ BOP I70™ Multi Ram ASSEMBLY</p>
<p>I70™ BLIND RAM ASSEMBLY</p>	<p>I70™ PIPE RAM ASSEMBLY</p>	<p>I70™ MULTI RAM ASSEMBLY</p>

Integrated Manufactured (OEM) API 16A Monogrammed Ram Blocks Available Upon Request

FRONT PACKER – TOP SEAL UNITS:

Description	Size	Pressure Rating	Material	Product Code	Weight Per Unit
Front Packer – Top Seal Unit	CSO	5k	NBR	70-401-801	8.40 lbs 3.81 kg
Front Packer – Top Seal Unit	2-3/8”	5k	NBR	70-401-801-1	8.40 lbs 3.81 kg
Front Packer – Top Seal Unit	2-7/8”	5k	NBR	70-401-801-2	8.40 lbs 3.81 kg
Front Packer – Top Seal Unit	3-1/2”	5k	NBR	70-401-801-3	8.20 lbs 3.72 kg
Front Packer – Top Seal Unit	4”	5k	NBR	70-401-801-4	8.80 lbs 4.00 kg
Front Packer – Top Seal Unit	4-1/2”	5k	NBR	70-401-801-5	8.80 lbs 4.00 kg
Front Packer – Top Seal Unit	5”	5k	NBR	70-401-801-6	8.60 lbs 3.90 kg
Front Packer – Top Seal Unit	5-1/2”	5k	NBR	70-401-801-7	8.60 lbs 3.90 kg
Front Packer – Top Seal Unit	6-5/8”	5k	NBR	70-401-801-8	8.40 lbs 3.81 kg
Front Packer – Top Seal Unit	7”	5k	NBR	70-401-801-9	8.40 lbs 3.81 kg
Front Packer – Top Seal Unit	7-5/8”	5k	NBR	70-401-801-10	8.40 lbs 3.81 kg
Front Packer – Top Seal Unit	8-5/8”	5k	NBR	70-401-801-11	7.80 lbs 3.54 kg
Front Packer – Top Seal Unit	9-5/8”	5k	NBR	70-401-801-12	7.80 lbs 3.54 kg

MULTI RAM – TOP SEALS AND FRONT PACKERS:

Description	Size	Pressure Rating	Material	Product Code	Weight Per Unit
Multi Ram – Top Seal	2-7/8” to 5”	5k	NBR	70-135101-V01	1.00 lbs 0.45 kg
Multi Ram – Top Seal	4-1/2” to 7”	5k	NBR	70-135101-V04	1.00 lbs 0.45 kg
Multi Ram - Front Packer	2-7/8” to 5”	5k	NBR	70-135101-V02	9.20 lbs 4.17 kg
Multi Ram – Front Packer	4-1/2” to 7”	5k	NBR	70-135101-V05	9.20 lbs 4.17 kg

The 13-5/8” – 5k I70™ Multi Ram Top Seal is different for the 2-7/8” to 5” and 4-1/2” to 7”

INTEGRATED OEM MANUFACTURED

RAM BOP FRONT PACKERS AND TOP SEALS

13-5/8" – 3 | 10k IU™ (U Style) FRONT PACKER & TOP SEALS

TOP SEAL



FRONT PACKER (Blind | Pipe | VBR | SBR)

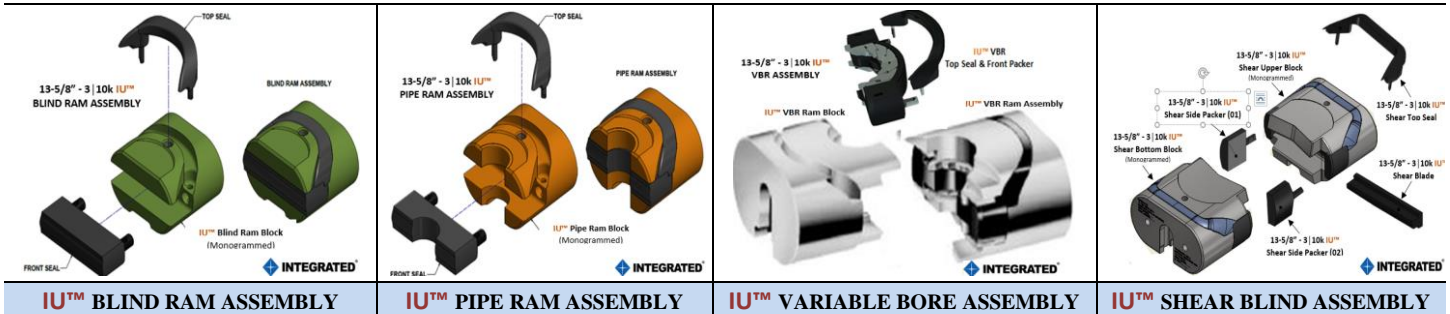

Integrated Manufactured (OEM) API 16A Monogrammed Ram Blocks Available Upon Request

TOP SEALS:

Description	Size	Pressure Rating	Material	Product Code	Weight Per Unit
Top Seal	CSO Thru 9-5/8"	3 10k	XNBR	70-1303-00022	2.00 lbs 0.91 kg

FRONT PACKERS: "I-RAM"

Description	Size	Pressure Rating	Material	Product Code	Weight Per Unit
Front Packer	CSO	3 10k	XNBR	70-1303-00027	17.00 lbs 8.62 kg
Front Packer	2-3/8"	3 10k	XNBR	70-1303-00041	16.00 lbs 7.26 kg
Front Packer	2-7/8"	3 10k	XNBR	70-1303-00042	16.00 lbs 7.260 kg
Front Packer	3-1/2"	3 10k	XNBR	70-1303-00043	19.00 lbs 8.62 kg
Front Packer	4"	3 10k	XNBR	70-1303-00044	18.80 lbs 8.53 kg
Front Packer	4-1/2"	3 10k	XNBR	70-1303-00045	18.20 lbs 8.26 kg
Front Packer	5"	3 10k	XNBR	70-1303-00046	17.00 lbs 7.71 kg
Front Packer	5-1/2"	3 10k	XNBR	70-1303-00047	16.60 lbs 7.53 kg
Front Packer	6-5/8"	3 10k	XNBR	70-1303-00049	17.00 lbs 7.71 kg
Front Packer	7"	3 10k	XNBR	70-1303-00020	20.60 lbs 9.34 kg
Front Packer	7-5/8"	3 10k	XNBR	70-1303-00050	19.40 lbs 8.80 kg
Front Packer	8-5/8"	3 10k	XNBR	70-1303-00051	14.90 lbs 8.11 kg
Front Packer	9-5/8"	3 10k	XNBR	70-1303-00021	12.80 lbs 5.80 kg

VARIABLE BORE RAM (VBR): TOP SEALS AND FRONT PACKERS:

Description	Size	Pressure Rating	Material	Product Code	Weight Per Unit
VBR – Top Seal	2-7/8" to 5" 3-1/2" to 5-1/2" 4-1/2" to 7"	3 10k	XNBR	70-1303-00022-V	2.00 lbs 0.91 kg
VBR – Front Packer	2-7/8" to 5"	3 10k	NBR	70-1303-00017	35.00 lbs 15.9 kg
VBR – Front Packer	3-1/2" to 5-1/2"	3 10k	NBR	70-1303-00017	35.00 lbs 15.9 kg
VBR – Front Packer	4-1/2" to 7"	3 10k	NBR	70-1303-00016	35.00 lbs 15.9 kg

SHEAR BLIND RAM (SBR): TOP SEALS | BLADE PACKER | SIDE PARKERS:

Description	Size	Pressure Rating	Material	Product Code	Weight Per Unit
SBR – Top Seal	13-5/8"	3 10k	XNBR	70-1303-00022	2.00 lbs 0.91 kg
SBR – Blade Packer	13-5/8"	3 10k	XNBR	95-13100023-BP	3.80 lbs 1.70 kg
SBR – Side Packer 01	13-5/8"	3 10k	XNBR	95-13100023-SP-01	2.80 lbs 1.27 kg
SBR – Side Packer 02	13-5/8"	3 10k	XNBR	95-13100023-SP-02	2.80 lbs 1.27 kg

For the 13-5/8" – 3/10k IU™, the Top Seal is the same for the CSO, all Pipe Sizes and SBR
 For 13-5/8" – 3/10k IU™, the VBR Front Packer for the 2-7/8" to 5" and 3-1/2" to 5-1/2" are the same. The only difference is the Ram block

**INTEGRATED OEM MANUFACTURED
RAM BOP REBUILD SEAL KITS**

RAM BOPS

IE™ (WSI Style) | IWP™ (LWP Style) | IWS™ (LWS Style)



INTEGRATED CARDED RAM SEAL KIT

INTEGRATED CARDED RAM SEAL KIT

IE™ (WSI Style) RAM SEAL KITS

Description Size	Size	Pressure	Product Code	Weight Per Unit
7-1/16" 5M IE™ Hydraulic Ram Complete Seal Kit	7-1/16"	5k	70-102-041K	3.00 lbs 1.36 kg

T81 (Cameron-Townsend) | SENTRY (Hydril) | LXT (NOV) | Chasovoy (NOV) - RAM SEAL KITS

Description Size	Size	Pressure	Product Code	Weight Per Unit
7-1/16" 5M T81 Hydraulic Ram Seal Kit	7-1/16"	3/5k	70-TH8100 (TH8100)	3.00 lbs 1.36 kg
7-1/16" 5M T81 Manual Ram Seal Kit	7-1/16"	5k	70-TM8100 (TM8100)	2.20 lbs 1.00 kg
7-1/16" 5M SENTRY Hydraulic Ram Seal Kit	7-1/16"	5k	70-3117169	4.00 lbs 1.00 kg
7-1/16" – 3/5M LXT Hydraulic Ram Complete Seal Kit	7-1/16"	3/5k	70-722001-LXT	4.00 lbs 1.00 kg
7-1/16" – 3/5M, Chasovoy Hydraulic Ram Seal Kit	7-1/16"	3/5k	70-185151	4.00 lbs 1.00 kg

IE™ - T81 COMBO RAM SEAL KIT

Description Size	Size	Pressure	Product Code	Weight Per Unit
7-1/16" 5M IE-T81 Hydraulic Ram Combo Seal Kit	7-1/16"	5k	70-IE81-5K	3.00 lbs 1.36 kg

IWP™ (LWP Style) RAM SEAL KITS

Description Size	Size	Pressure	Product Code	Weight Per Unit
9" 3M IWP™ Ram Complete Seal Kit	9"	3K	70-102-040	3.40 lbs 1.54 kg

IWS™ (LWS Style) RAM SEAL KITS

Description Size	Size	Pressure	Product Code	Weight Per Unit
7-1/16" 5M IWS™ Hydraulic Ram Complete Seal Kit	7-1/16"	5k	82-880000	10.20 lbs 4.63 kg
11" 3M IWS™ Hydraulic Ram Complete Seal Kit	11"	3K	82-880001	20.00 lbs 9.07 kg
11" 3M IWS™ Hydraulic Ram Soft Goods Seal Kit	11"	3K	82-880001-SG	4.00 lbs 1.80 kg
11" 5M IWS™ Hydraulic Ram Complete Seal Kit	11"	5K	82-881100	20.00 lbs 9.07 kg
11" 5M IWS™ Hydraulic Ram Soft Goods Seal Kit	11"	5K	82-881100-SG	4.00 lbs 1.80 kg
13-5/8" 5M IWS™ Hydraulic Ram Complete Seal Kit	13-5/8"	5K	82-80011	22.00 lbs 9.98 kg
13-5/8" 5M IWS™ Hydraulic Ram Soft Goods Seal Kit	13-5/8"	5K	82-80011-SG	4.00 lbs 1.80 kg

**INTEGRATED OEM MANUFACTURED
RAM BOP REBUILD SEAL KITS**

**RAM BOPS
IU™ (U Style)**



INTEGRATED CARDED RAM SEAL KIT

INTEGRATED CARDED RAM SEAL KIT

IU™ (U Style) RAM SEAL KITS

Description Size	Size	Pressure	Product Code	Weight Per Unit
7-1/16" 3M-15M IU™ Ram Standard Complete Seal Kit	7-1/16"	3 15K	95-076449092-SB-CRK	6.50 lbs 2.95 kg
7-1/16" 3M-15M IU™ Ram Standard Soft Goods Seal Kit	7-1/16"	3 15K	95-076449092-SB-SGK	2.50 lbs 1.15 kg
7-1/16" 3M-15M IU™ Ram Standard Hard Goods Seal Kit	7-1/16"	3 15K	95-076449062-SB-HGK	4.00 lbs 1.80 kg
7-1/16" 3M-15M IU™ Ram Large Bore Complete Seal Kit	7-1/16"	3 15K	95-07644860-LB-CRK	8.00 lbs 3.63 kg
7-1/16" 3M-15M IU™ Ram Large Bore Soft Goods Seal Kit	7-1/16"	3 15K	95-07644860-LB-SGK	2.50 lbs 1.15 kg
7-1/16" 3M-15M IU™ Ram Large Bore Hard Goods Seal Kit	7-1/16"	3 15K	95-07644860-LB-HGK	4.00 lbs 1.80 kg
7-1/16" 3M-15M IU™ Ram Tandem Booster Complete Seal Kit	7-1/16"	3 15K	95-0702232403-TB-CRK	7.00 lbs 3.17 kg
7-1/16" 3M-15M IU™ Ram Tandem Booster Soft Goods Seal Kit	7-1/16"	3 15K	95-0702232403-TB-SGK	1.75 lbs 0.80 kg
7-1/16" 3M-15M IU™ Ram Tandem Booster Hard Goods Seal Kit	7-1/16"	3 15K	95-0702232403-TB-HGK	5.25 lbs 2.27 kg
7-1/16" 3M-15M IU™ Ram Mud Seal Kit	7-1/16"	3 15K	70-0703-MSK	1.00 lbs 0.45 kg
11" 3M-10M IU™ Ram Standard Complete Seal Kit	11"	3 10K	95-116449092-SB-CRK	10.00 lbs 4.54 kg
11" 3M-10M IU™ Ram Standard Soft Goods Seal Kit	11"	3 10K	95-116449092-SB-SGK	6.00 lbs 2.74 kg
11" 3M-10M IU™ Ram Standard Hard Goods Seal Kit	11"	3 10K	95-116449092-SB-HGK	4.00 lbs 1.80 kg
11" 3M-10M IU™ Ram Large Bore Complete Seal Kit	11"	3 10K	95-11644860-LB-CRK	14.00 lbs 6.35 kg
11" 3M-10M IU™ Ram Large Bore Soft Goods Seal Kit	11"	3 10K	95-11644860-LB-SGK	10.00 lbs 4.55 kg
11" 3M-10M IU™ Ram Large Bore Hard Goods Seal Kit	11"	3 10K	95-11644860-LB-HGK	4.00 lbs 1.80 kg
11" 3M-10M IU™ Ram Tandem Booster Complete Seal Kit	11"	3 10K	95-11132164148-TB-CRK	10.00 lbs 4.54 kg
11" 3M-10M IU™ Ram Tandem Booster Soft Goods Seal Kit	11"	3 10K	95-11132164148-TB-SGK	2.25 lbs 1.02 kg
11" 3M-10M IU™ Ram Tandem Booster Hard Goods Seal Kit	11"	3 10K	95-11132164148-TB-HGK	7.75 lbs 3.52 kg
13-5/8" 3M-10M IU™ Ram Standard Complete Seal Kit	13-5/8"	3 10K	95-136449092-SB-CRK	12.00 lbs 4.54 kg
13-5/8" 3M-10M IU™ Ram Standard Soft Goods Seal Kit	13-5/8"	3 10K	95-136449092-SB-SGK	8.00 lbs 3.63 kg
13-5/8" 3M-10M IU™ Ram Standard Hard Goods Seal Kit	13-5/8"	3 10K	95-136449092-SB-HGK	4.00 lbs 1.80 kg
13-5/8" 3M-10M IU™ Ram Large Bore Complete Seal Kit	13-5/8"	3 10K	95-13644860-LB-CRK	16.00 lbs 6.35 kg
13-5/8" 3M-10M IU™ Ram Large Bore Soft Goods Seal Kit	13-5/8"	3 10K	95-13644860-LB-SGK	12.00 lbs 4.55 kg
13-5/8" 3M-10M IU™ Ram Large Bore Hard Goods Seal Kit	13-5/8"	3 10K	95-13644860-LB-HGK	4.00 lbs 1.80 kg
13-5/8" 3M-10M IU™ Ram Tandem Booster Complete Seal Kit	13-5/8"	3 10K	95-11132164148-TB-CRK	10.00 lbs 4.54 kg
13-5/8" 3M-10M IU™ Ram Tandem Booster Soft Goods Seal Kit	13-5/8"	3 10K	95-11132164148-TB-SGK	2.25 lbs 1.02 kg
13-5/8" 3M-10M IU™ Ram Tandem Booster Hard Goods Seal Kit	13-5/8"	3 10K	95-11132164148-TB-HGK	7.75 lbs 3.52 kg

**INTEGRATED OEM MANUFACTURED
INDIVIDUAL SEALS**

RAM DOOR SEALS

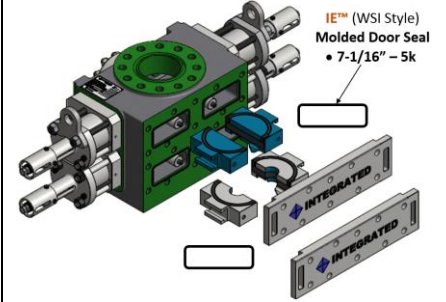
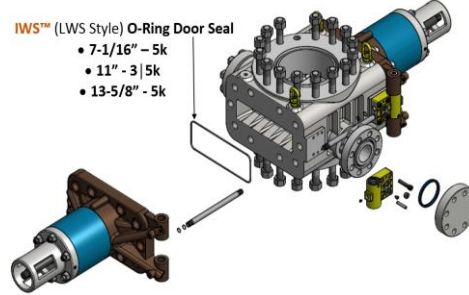
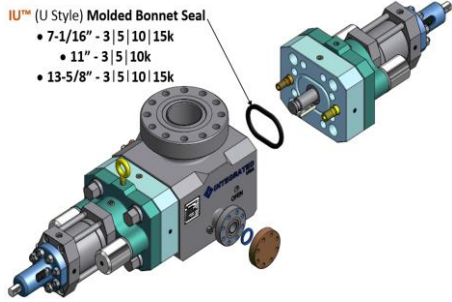

**7-1/16" IU™
(U Style)
Bonnet Door Seal**



**11" IU™
(U Style)
Bonnet Door Seal**



**13-5/8" IU™
(U Style)
Bonnet Door Seal**



**7-1/16" IWS™
(LWS Style)
O-Ring Door Seal**



**11" IWS™
(LWS Style)
O-Ring Door Seal**

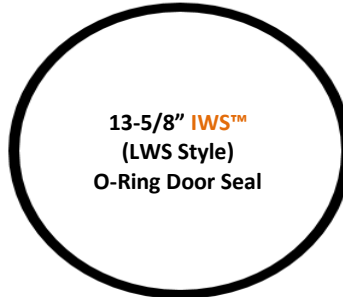

**13-5/8" IWS™
(LWS Style)
O-Ring Door Seal**



**7-1/16" IE™
(WSI Style)
Molded Door Seal**

IU™ (U Style) Bonnet Door Seals

IWS™ (LWS Style) O-Ring Door Seals

IE™ (WSI Style) Molded Door Seal

DOOR SEALS

Description Size	Size	Pressure	Product Code	Weight Per Unit
7-1/16" 5M IE™ Door Seal (O-Ring Style) (442-70)	7-1/16"	5k	70-0705-00025	00 lbs 00 kg
7-1/16" 5M IE™ Door Seal High Temperature (O-Ring Style)	7-1/16"	5k	70-0705-00025-HT	00 lbs 00 kg
7-1/16" 5M IE™ Door Seal (Molded Style)	7-1/16"	5k	17-110-102	00 lbs 00 kg
7-1/16" 5M LWS Door Seal (451-90)	7-1/16"	5k	17-100-100	00 lbs 00 kg
7-1/16" 3M-15M IU™ Door Seal (Molded Style)	7-1/16"	3 15K	82-190-6012	00 lbs 00 kg
9" 3M IWP™ Door Seal (451-90)	9"	3k	17-100-100	00 lbs 00 kg
11" 3M IWS™ Door Seal (457-90)	11"	3k	70-02110320514	00 lbs 00 kg
11" 5M IWS™ Door Seal (460-90)	11"	5k	70-02110520514	00 lbs 00 kg
11" 3M-10M IU™ Door Seal (Molded Style)	11"	3 10k	82-906-013	00 lbs 00 kg
13-5/8" 5M IWS™ Door Seal (460-90)	13-5/8"	5k	70-02110520514	00 lbs 00 kg
13-5/8" 3M-10M IU™ Door Seal (Molded Style)	13-5/8"	3 10k	17-080-067	00 lbs 00 kg

**INTEGRATED OEM MANUFACTURED
ANNULAR BOP REBUILD CARDED SEAL KITS**

ANNULAR BOPS
7-1/16" | 9" | 11" | 13-5/8" | 21-1/4"
ISA™ (Spherical Annular Style) | IK™ (GK Style)

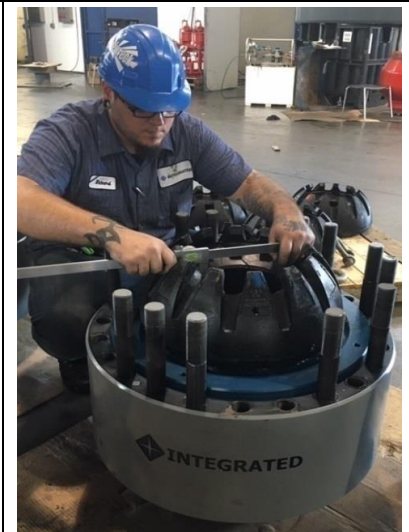

COMPLETE CARDED ANNULAR SEAL KIT

**ANNULAR INSPECTION PRIOR TO
SEAL & PACKING ELEMENT
INSTALLATION**

ISA™ | SPHERICAL ANNULAR SEAL KITS

Description Size	Size	Pressure	Product Code	Weight Per Unit
7-1/16" 3 5M Spherical Annular ISA™ Seal Kit	7-1/16"	5k	82-221-55079	7.00 lbs 3.18 kg
7-1/16" 3 5M Spherical Annular ISA™ Seal Kit w/Wear Band	7-1/16"	5k	82-221-55079-WB	10.00 lbs 4.54 kg
9" 3M Spherical Annular ISA™ Seal Kit	9"	5k	82-221-55077	7.00 lbs 3.18 kg
9" 3M Spherical Annular ISA™ Seal Kit w/Wear Band	9"	5k	82-221-55077-WB	10.00 lbs 4.54 kg
11" 3M Spherical Annular ISA™ Seal Kit	11"	3k	82-221-55075	13.00 lbs 5.90 kg
11" 3M Spherical Annular ISA™ Seal Kit w/Wear Band	11"	3k	82-221-55075-WB	15.00 lbs 6.80 kg
11" 5M Spherical Annular ISA™ Seal Kit	11"	5k	82-221-55030	14.00 lbs 6.35 kg
11" 5M Spherical Annular ISA™ Seal Kit w/Wear Band	11"	5k	82-221-55030-WB	16.00 lbs 7.26 kg
13-5/8" 3 5M Spherical Annular ISA™ Seal Kit	13-5/8"	5k	82-221-55070	20.00 lbs 9.07 kg
13-5/8" 3 5M Spherical Annular ISA™ Seal Kit w/Wear Band	13-5/8"	5k	82-221-55070-WB	23.00 lbs 10.43 kg
21-1/4" 2M Spherical Annular ISA™ Seal Kit	21-1/4"	2k	82-221-55067	28.00 lbs 12.70 kg
21-1/4" 2M Spherical Annular ISA™ Seal Kit w/Wear Band	21-1/4"	2k	82-221-55067-WB	31.00 lbs 14.06 kg

IK™ | GK ANNULAR SEAL KITS

Description Size	Size	Pressure	Product Code	Weight Per Unit
7-1/16" 5M Annular IK™ Seal Kit	7-1/16"	5k	82-200-50684	12.00 lbs 5.44 kg
11" 5M Annular IK™ Seal Kit	11"	5k	82-200-50688	16.00 lbs 7.26 kg
13-5/8" 5M Annular IK™ Seal Kit	13-5/8"	5k	82-200-50690	19.00 lbs 8.62 kg

SPHERICAL ANNULAR WEAR BAND

Description Size	Size	Product Code	Weight Per Unit
1" Wear Band x .093" (per inch)	1" x .093"	95-05110520172	00 lbs 00 kg
1" Wear Band x .125" (per foot)	1" x .125"	95-49223-1000	00 lbs 00 kg
0.5" Wear Band x .093" (per inch)	.5" x .093"	95-05110520180	00 lbs 00 kg
0.5" Wear Band x .125" (per foot)	.5" x .125"	95-49223-0500	00 lbs 00 kg

➤ Wear Bands are available in many different materials | Wear Bands are offered in different sizes & lengths

**INTEGRATED OEM MANUFACTURED
ANNULAR BOP SEAL BREAKDOWN**

ISA™ (Spherical Annular Style) SEAL KIT BREAKDOWN

ISA™ | SPHERICAL ANNULAR SEAL KITS

SEAL DESCRIPITON	7-1/16" - 3 5K	9" - 3K	11" - 3K	11" - 5K	13-5/8" - 3 5K	21-1/4" - 2K
Complete Carded Seal Kit Number	82-221-55079-WB	82-221-55077-WB	82-221-55075-WB	82-221-55030-WB	82-221-55070-WB	82-221-55067-WB
INDIVIDUAL SEALS IN EACH KIT						
Adapter ID O-Ring	82-221-30405	82-221-31109	95-05110320182	95-05110520181	95-06130520176	30-000020
Adapter OD O-Ring	82-221-30408	82-221-30784	95-05110320181	95-05110520176	95-06130520181	30-000027
Lip Seal Adapter Ring ID Upper	82-221-31104	82-221-31145	95-05110320176	95-05110520178	95-06130520178	30-000026
Wear Band - Adapter Ring	95-05110520172	95-05110520172	95-05110520172	95-05110520172	95-05110520172	95-05110520172
Lip Seal Adapter Ring ID Lower	82-221-31002	82-221-31037	95-05110320177	95-05110520177	95-06130520177	30-000024
Lip Seal Piston OD	82-221-30780	82-221-31012	95-05110320175	95-05110520175	95-06130520175	30-000019
Wear Band - Piston	95-05110520172	95-05110520172	95-05110520172	95-05110520172	95-05110520172	95-05110520172
Seal Piston ID Upper	82-221-31105	82-221-31110	95-05110320173	95-05110520173	95-06130520173	30-000022
Seal Piston ID Lower	82-221-31000	82-221-31002	95-05110320174	95-05110520174	95-06130520174	30-000023
Wear Ban - Lower Housing	95-05110520180	95-05110520180	95-05110520180	95-05110520180	95-05110520180	95-05110520180
Piston Skirt Seal	Not Required	Not Required	Not Required	Not Required	Not Required	95-05110520180
<i>I-Filter™</i> Seal	95-0705-00012 Not in Complete Kit	N/A	N/A	N/A	N/A	N/A

IK™ (GK Style) SEAL KIT BREAKDOWN

IK™ | GK ANNULAR SEAL KITS

SEAL DESCRIPITON	7-1/16" - 3K	7-1/16" - 5k	11" - 3k	11" - 5k	13-5/8" - 3K	13-5/8" - 5K	21-1/4" - 2k
Complete Carded Seal Kit Master No.	82-200-50683	82-200-50684	82-200-50687	82-200-50688	82-200-50689	82-200-50690	82-200-50702
INDIVIDUAL SEALS IN EACH KIT							
Head Gasket (Cap Seal)	82-200-31602	82-200-30690	82-200-31809	82-200-31402	82-200-30738	82-200-38150	82-200-37377
Upper U Seal	82-200-31608	82-200-30689	82-200-31808	82-200-31408	82-200-30736	82-200-38151	82-200-37379
Middle U Seal	82-200-30604	82-200-30688	82-200-31807	82-200-30736	82-200-30737	82-200-38152	Not-Required
Inner U Seals	Non-Required	Not-Required	Not-Required	Not-Required	Not-Required	Not-Required	82-200-37380
Lower U Seals	82-200-15614	82-200-30705	82-200-31604	82-200-32599	82-200-30735	82-200-38165	82-200-37378

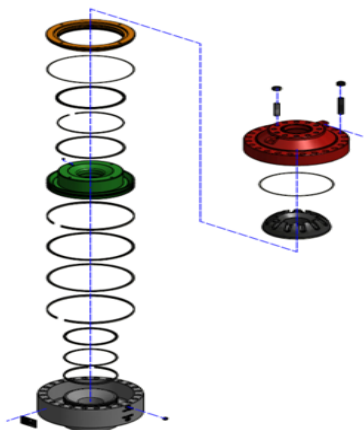

**ISA™
(Spherical Style)
Annular BOP
Seal & Component
Parts Breakdown**

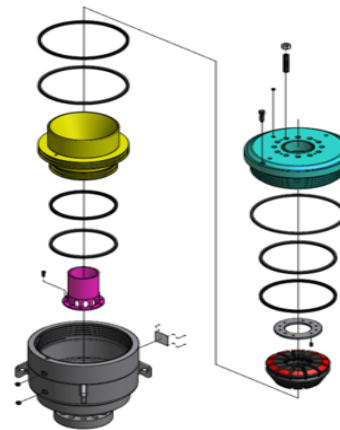

**IK™
(GK Style)
Annular BOP
Seal & Component
Parts Breakdown**

**INTEGRATED OEM MANUFACTURED
INDIVIDUAL SEALS**

MISCELLANEOUS SEALS (Soft Goods) and INIDIVIDUAL HARDWARE



**INTEGRATED SEALS
Miscellaneous**

ISA™ SPHERICAL ANNULAR INDIVIDUAL SEALS

Description Size	Size	Pressure	Product Code	Weight Per Unit
Adapter Top Seal	7-1/16"	5k	82-221-10405	00 lbs 00 kg
<i>I-Filter™</i> Wiper Seal	7-1/16"	5k	95-0705-00012	00 lbs 00 kg
Adapter Top Seal	9"	3k	82-221-31145	00 lbs 00 kg
Adapter Top Seal	11"	3k	95-05110320176	00 lbs 00 kg
Adapter Top Seal	11"	5k	95-05110520176	00 lbs 00 kg
Adapter Top Seal	13-5/8"	5k	95-05130520176	00 lbs 00 kg
Adapter Top Seal	21-1/4"	2k	30-000020	00 lbs 00 kg

IU™ RAM INDIVIDUAL HARDWARE PARTS (U Style)

Description Size	Size	Pressure	Product Code	Weight Per Unit
Connecting Rod Seal	7-1/16"	3 15k	82-117-4137	00 lbs 00 kg
Modified Washer	7-1/16"	3 15k	82-485-004	00 lbs 00 kg
Retaining Ring	7-1/16"	3 15k	82-485-003	00 lbs 00 kg
Back Up Ring	7-1/16"	3 15k	82-217-9221	00 lbs 00 kg
Packing Ring	7-1/16"	3 15k	82-124-6936	00 lbs 00 kg
Connecting Rod Seal	11"	3 10k	82-117-4138	00 lbs 00 kg
Modified Washer	11"	3 10k	82-485-002	00 lbs 00 kg
Retaining Ring	11"	3 10k	82-485-001	00 lbs 00 kg
Back Up Ring	11"	3 10k	82-219-7222	00 lbs 00 kg
Packing Ring	11"	3 10k	82-124-6938	00 lbs 00 kg
Connecting Rod Seal	13-5/8"	3 10k	17-080-053	00 lbs 00 kg
Modified Washer	13-5/8"	3 10k	17-080-064	00 lbs 00 kg
Retaining Ring	13-5/8"	3 10k	17-080-061	00 lbs 00 kg
Back Up Ring	13-5/8"	3 10k	17-080-054	00 lbs 00 kg
Packing Ring	13-5/8"	3 10k	17-080-051	00 lbs 00 kg

IWS™ | IWP™ RAM INDIVIDUAL HARDWARE PARTS (LWS & LWP Styles)

Description Size	Size Pressure Model	Product Code	Weight Per Unit
Packing Adapter	7-1/16" - 5k IWS™ & 11" - 3k IWS™	70-02110320242	00 lbs 00 kg
Packing Adapter	7-1/16" - 3k IWS™ & 9" - 3k IWP™	70-300-013	00 lbs 00 kg
Thrust Bushing	7-1/16" - 5k IWS™ & 9" - 3k IWP™ & 11" - 3k IWS™	70-02110320244	00 lbs 00 kg
Packing Adapter	11" - 5k IWS™ & 13-5/8" - 5k IWS™	70-02110520242	00 lbs 00 kg
Thrust Bushing	11" - 5k IWS™ & 13-5/8" IWS™	70-02110520526	00 lbs 00 kg

**INTEGRATED OEM MANUFACTURED
PULSATION DAMPENER DIAPHRAGMS**

IPD™ (Production Style) | IKD™ (K Drilling Style) | EMSCO Style

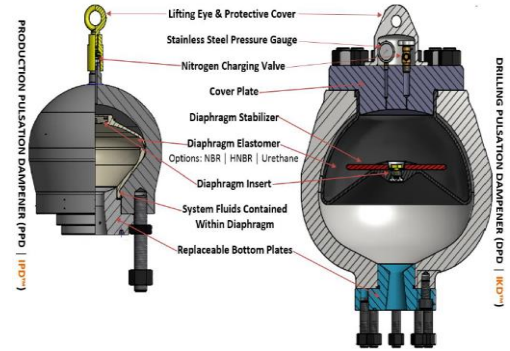

INTEGRATED DIAPHRAGMS IPD™ STYLE | IKD™ STYLE | EMSCO STYLE **INTEGRATED PPD & DPD PULSATION DAMPENERS** **INTEGRATED PULSATION DAMPENERS (IPD™ | IKD™)**

IPD™ - PPD (Production Pulsation Dampener Diaphragms)

Description	Size	Material	Product Code	Weight Per Unit
1 Gallon PPD Diaphragm	1 gal	NBR	73-011004	4.00 lbs 1.80 kg
1 Gallon PPD Diaphragm	1 gal	HNBR	73-012004	4.00 lbs 1.80 kg
1 Gallon PPD Diaphragm	1 gal	Urethane	73-015004	4.00 lbs 1.80 kg
1 Gallon PPD Diaphragm	1 gal	FKM	73-013004	4.00 lbs 1.80 kg
2.5 Gallon PPD Diaphragm	2.5 gal	NBR	73-251004	7.00 lbs 3.20 kg
2.5 Gallon PPD Diaphragm	2.5 gal	HNBR	73-252004	7.00 lbs 3.20 kg
2.5 Gallon PPD Diaphragm	2.5 gal	Urethane	73-255004	7.00 lbs 3.20 kg
2.5 Gallon PPD Diaphragm	2.5 gal	FKM	73-253004	7.00 lbs 3.20 kg
5 Gallon PPD Diaphragm	5 gal	NBR	73-051004	10.00 lbs 4.50 kg
5 Gallon PPD Diaphragm	5 gal	HNBR	73-052004	10.00 lbs 4.50 kg
5 Gallon PPD Diaphragm	5 gal	Urethane	73-055004	10.00 lbs 4.50 kg
5 Gallon PPD Diaphragm	5 gal	FKM	73-053004	10.00 lbs 4.50 kg

IPD™ - PPD (Production Pulsation Dampener Diaphragms) | IKD™ - DPD (Drilling Pulsation Dampener Diaphragms)

Description	Size	Material	Product Code	Weight Per Unit
10 Gallon PPD Diaphragm	10 gal	NBR	73-101004	17.00 lbs 7.70 kg
10 Gallon PPD Diaphragm	10 gal	HNBR	73-102004	17.00 lbs 7.70 kg
10 Gallon PPD Diaphragm	10 gal	Urethane	73-105004	17.00 lbs 7.70 kg
10 Gallon PPD Diaphragm	10 gal	FKM	73-103004	17.00 lbs 7.70 kg
20 Gallon PPD Diaphragm	20 gal	NBR	73-201004	28.00 lbs 12.70 kg
20 Gallon PPD Diaphragm	20 gal	HNBR	73-202004	28.00 lbs 12.70 kg
20 Gallon PPD Diaphragm	20 gal	Urethane	73-205004	28.00 lbs 12.70 kg
20 Gallon PPD Diaphragm	20 gal	FKM	73-203004	28.00 lbs 12.70 kg

EMSCO (PD Diaphragms)

Description	Size	Material	Product Code	Weight Per Unit
PD 45 Diaphragm	10 gal	NBR	71-6922-4503	16.00 lbs 7.26 kg
PD 45 Diaphragm	10 gal	HNBR	71-6922-4507	16.00 lbs 7.26 kg
PD 45 Diaphragm	10 gal	Urethane	71-6922-4505	16.00 lbs 7.26 kg
PD 45 Diaphragm	10 gal	FKM	71-6922-4509	16.00 lbs 7.26 kg
PD 55 Diaphragm	20 gal	NBR	71-6922-5503	26.00 lbs 11.80 kg
PD 55 Diaphragm	20 gal	HNBR	71-6922-5507	26.00 lbs 11.80 kg
PD 55 Diaphragm	20 gal	Urethane	71-6922-5505	26.00 lbs 11.80 kg
PD 55 Diaphragm	20 gal	FKM	71-6922-5509	26.00 lbs 11.80 kg
PD 55A Diaphragm (w/insert)	20 gal	NBR	71-6922-5503A	28.00 lbs 12.70 kg
PD 55A Diaphragm (w/insert)	20 gal	HNBR	71-6922-5507A	28.00 lbs 12.70 kg
PD 55A Diaphragm (w/insert)	20 gal	Urethane	71-6922-5505A	28.00 lbs 12.70 kg
PD 55A Diaphragm (w/insert)	20 gal	FKM	71-6922-5509A	28.00 lbs 12.70 kg

**INTEGRATED OEM MANUFACTURED
PULSATION DAMPENER SPARE PARTS**

PULSATION DAMPENER MISCELLANEOUS ITEMS



PD | DPD STABILIZER PLATES

PD | DPD CHARGING HOSES & GAUGE ASSEMBLIES

PPD (Production Pulsation Dampener): 1 Gallon

Description	Size	Product Code	Weight Per Unit
1 Gallon PPD Charging Valve	1 gal	71-210-014	0.25 lbs 0.11 kg
1 Gallon PPD Charging Hose Assembly	1 gal	71-200-021	6.00 lbs 2.72 kg

PPD (Production Pulsation Dampener): 2.5 Gallon

Description	Size	Product Code	Weight Per Unit
2.5 Gallon PPD Charging Valve	2.5 gal	71-210-014	0.25 lbs 0.11 kg
2.5 Gallon PPD Charging Hose Assembly	2.5 gal	71-200-021	6.00 lbs 2.72 kg

PPD (Production Pulsation Dampener): 5 Gallon

Description	Size	Product Code	Weight Per Unit
5 Gallon PPD Charging Valve	5 gal	71-210-014	0.25 lbs 0.11 kg
5 Gallon PPD Charging Hose Assembly	5 gal	71-200-021	6.00 lbs 2.72 kg

PPD | DPD (Production Pulsation Dampener | Drilling Pulsation Dampener): 10 Gallon

Description	Size	Product Code	Weight Per Unit
10 Gallon DPD Stabilizer Plate	10 gal	73-201005	2.00 lbs 0.91 kg
10 Gallon Bottom Gasket, HSN	10 gal	71-100-002	0.50 lbs 0.23 kg
10 Gallon PPD Charging Valve	10 gal	71-210-014	2.00 lbs 0.91 kg
10 Gallon PPD Charging Hose Assembly	10 gal	71-200-021	6.00 lbs 2.72 kg
10 Gallon DPD Charging Hose Assembly	10 gal	71-200-020	6.00 lbs 2.72 kg

PPD | DPD (Production Pulsation Dampener | Drilling Pulsation Dampener): 20 Gallon

Description	Size	Product Code	Weight Per Unit
20 Gallon PPD / DPD Stabilizer	20 gal	73-2000005	5.00 lbs 2.27 kg
20 Gallon DPD Stabilizer Plate	20 gal	73-201005	2.00 lbs 0.91 kg
20 Gallon Bottom Gasket, HSN	20 gal	71-100-004	0.50 lbs 0.23 kg
20 Gallon PPD Charging Valve	20 gal	71-210-014	2.00 lbs 0.91 kg
20 Gallon PPD Charging Hose Assembly	20 gal	71-200-021	6.00 lbs 2.72 kg
20 Gallon DPD Charging Hose Assembly	20 gal	71-200-020	6.00 lbs 2.72 kg

PD-45

Description	Size	Product Code	Weight Per Unit
PD-45 Charging Valve	PD-45	71-6922-402FMAC	3.00 lbs 1.36 kg
PD-45 Charging Hose Assembly	PD-45	71-6922-040	6.00 lbs 2.72 kg

PD-55

Description	Size	Product Code	Weight Per Unit
PD-55 Charging Valve	PD-55	71-6922-402FMAC	3.00 lbs 1.36 kg
PD-55 Charging Hose Assembly	PD-55	71-6922-040	6.00 lbs 2.72 kg

PD-55A

Description	Size	Product Code	Weight Per Unit
PD-55A Stabilizer	PD-55A	71-6922-0109	5.00 lbs 2.27 kg

**INTEGRATED OEM MANUFACTURED
PIPE WIPERS**

DRILLING PIPE WIPERS



PIPE WIPERS: Standard Material – Black is NR | Red is NR-NBR

Description Size	Size	Color	Product Code	Weight Per Unit
9" OD Lo-Profile	9"	Black	80-100-TF09T	6.00 lbs 2.70 kg

Description Size	Size	Color	Product Code	Weight Per Unit
14" OD Flat	14"	Black	80-100-TF14	15.00 lbs 6.80 kg
14" OD Flat	14"	Red	80-100-TF14R	15.00 lbs 6.80 kg
14" OD Split Dual	14"	Black	80-100-SD14	20.00 lbs 9.10 kg
14" OD Split Dual	14"	Red	80-100-SD14R	20.00 lbs 9.10 kg

Description Size	Size	Color	Product Code	Weight Per Unit
17" OD Flat	17"	Black	80-100-TF17	17.00 lbs 7.70 kg
17" OD Flat	17"	Red	80-100-TF17R	17.00 lbs 7.70 kg
17" OD Split Dual	17"	Black	80-100-SD17	23.00 lbs 10.50 kg
17" OD Split Dual	17"	Red	80-100-SD17R	23.00 lbs 10.50 kg

Description Size	Size	Color	Product Code	Weight Per Unit
19" OD Flat	19"	Black	80-100-TF19	19.00 lbs 8.60 kg
19" OD Flat	19"	Red	80-100-TF19R	19.00 lbs 8.60 kg
19" OD Split Dual	19"	Black	80-100-SD19	31.00 lbs 14.10 kg
19" OD Split Dual	19"	Red	80-100-SD19R	31.00 lbs 14.10 kg

Description Size	Size	Color	Product Code	Weight Per Unit
22" OD Flat	22"	Black	80-100-TF22	22.00 lbs 10.00 kg
22" OD Flat	22"	Red	80-100-TF22R	22.00 lbs 10.00 kg
22" OD Split Dual	22"	Black	80-100-SD22	45.00 lbs 20.40 kg
22" OD Split Dual	22"	Red	80-100-SD22R	45.00 lbs 20.40 kg

Description Size	Size	Color	Product Code	Weight Per Unit
24" OD Flat	24"	Black	80-100-TF24	24.00 lbs 10.90 kg
24" OD Flat	24"	Red	80-100-TF24R	24.00 lbs 10.90 kg
24" OD Split Dual	24"	Black	80-100-SD24	50.00 lbs 22.70 kg
24" OD Split Dual	24"	Red	80-100-SD24R	50.00 lbs 22.70 kg

Description Size	Size	Color	Product Code	Weight Per Unit
26" OD Flat	26"	Black	80-100-TF26	26.00 lbs 11.80 kg
26" OD Flat	26"	Red	80-100-TF26R	26.00 lbs 11.80 kg

PIPE WIPERS CUTTER ASSEMBLY:

Description Size	Product Code	Weight Per Unit
Pipe Wiper Cutting Assembly	81-100-7005A	26.00 lbs 11.80 kg
Wiper Cutting Replacement Blade	81-100-70055	26.00 lbs 11.80 kg

INTEGRATED OEM MANUFACTURED**ELASTOMERIC MATERIAL DESCRIPTIONS****POLYISOPRENE****➤ NR - ASTM D1418 Designation:**

Natural Rubber features high tensile strength, high resilience, high abrasion and high tear resistance properties, with a good friction surface and excellent adhesion to metals. Until the invention of synthetic elastomers in the 1930's, Natural Rubber was the only polymer available for O-ring manufacture. Natural Rubber features good resistance to organic acids and alcohols, with moderate resistance to aldehydes.

ACRYLONITRILE BUTADIENE POLYMER**➤ NBR - ASTM D1418 Designation:**

Nitrile rubber (NBR) is the general term for acrylonitrile butadiene copolymer. The acrylonitrile content of nitrile sealing compounds varies considerably (18% to 50%) and influences the physical properties of the finished material. The higher the acrylonitrile content, the better the resistance to oil and fuel. At the same time, elasticity and resistance to compression set is adversely affected. In view of these opposing realities, a compromise is often drawn, and a medium acrylonitrile content selected. NBR has good mechanical properties when compared with other elastomers and high wear resistance. NBR is not resistant to weathering and ozone.

CARBOXYLATED ACRYLONITRILE BUTADIENE POLYMER**➤ XNBR - ASTM D1418 Designation:**

Carboxylated Nitrile is similar to Nitrile rubber, but the polymer backbone has been chemically modified with Carboxylic Acid containing group. This result is XNBR with more excellent abrasion and tear resistance than traditional NBR.

HYDROGENATED ACRYLONITRILE BUTADIENE POLYMER**➤ HNBR - ASTM D1418 Designation:**

HNBR is widely used in oil industry and maintains excellent resistance to motor oils, sour gas, amine/oil mixtures, oxidized fuels, and lubricating oils. HNBR is resistant to mineral oil-based hydraulic fluids, animal and vegetable fats, diesel fuel, ozone, sour gas, dilute acids and bases. It also resists new bio-oils (biological oils). It is suitable for high dynamic loads and has a good abrasion resistance.

FLUOROCARBON POLYMER**➤ FKM - ASTM D1418 Designation:**

FKM has excellent resistance to high temperatures, ozone, oxygen, mineral oil, synthetic hydraulic fluids, fuels, aromatics and many organic solvents and chemicals. Low temperature resistance is normally not favorable and for static applications is limited to approximately -26°C (-15°F) although certain compounds are suitable down to -46°C (-50°F). Under dynamic conditions, the lowest service temperature is between -15°C and -18°C (5°F and 0°F). Gas permeability is very low and similar to that of butyl rubber. Special FKM compounds exhibit an improved resistance to acids and fuels.

ULTRA HIGH MOLECULAR WEIGHT POLYETHYLENE**➤ UHMW:**

UHMW is a thermoplastic material made up of extremely long chains of polyethylene. The polyethylene chains give the material a high abrasion resistance. Its high wear strength makes it most suitable for applications such as stripping where abrasion is its most prolific.

POLYURETHANE**➤ URETHANE:**

Polyurethane elastomers, as a class, have excellent wear resistance, high tensile strength and high elasticity in comparison with any other elastomers. Permeability is good and comparable with butyl.

INTEGRATED OEM MANUFACTURED

ELASTOMERIC MATERIAL GENERAL COMPATIBILITY GUIDE

Application	Natural Rubber (NR)	Nitrile (NBR)	Carboxylated Nitrile (XNBR)	Hydrogenated Nitrile (HNBR)	Viton (FKM)
Tensile Strength (Psi)	Over 3000	Over 2000	Over 3000	Over 3000	Over 1000
Hardness (Shore A)	30 - 90	40 - 90	40 - 90	40 - 90	40 - 90
Adhesion to metals	Excellent	Excellent	Good	Excellent	Fair to Good
Adhesion to fabrics	Excellent	Good	Good	Good	Good
Tear Resistance	Good	Fair	Excellent	Good	Fair to Good
Abrasion Resistance	Excellent	Good	Excellent	Excellent	Good
Compression Set	Excellent	Good	Excellent	Good	Good
Resilience - Hot	Excellent	Fair	Good	Good	Good
Resilience - Cold	Excellent	Fair	Good	Good	Fair
Dielectric Strength	Excellent	Poor	Good	Good	Good
Electrical Insulation	Good to Excellent	Poor	Good	Good	Good
Impermeability to Gases	Good	Excellent	Excellent	Excellent	Excellent
Acid Resistance - Dilute	Fair to Good	Good	Good	Good	Good - Excellent
Acid Resistance - Concentrated	Fair to Good	Good	Good	Good	Excellent
Solvent Resistance - Aliphatic Hydrocarbons	Poor	Excellent	Excellent	Excellent	Excellent
Solvent Resistance - Aromatic Hydrocarbons	Poor	Good	Good	Excellent	Excellent
Solvent Resistance - Oxygenated	Poor	Poor	Good	Excellent	Poor
Solvent Resistance - Lacquer	Poor	Fair	Good	Good	Poor
Solvent Resistance - Lubricating Oils	Poor	Good	Good	Excellent	Excellent
Resistance - Oil & Gas	Poor	Excellent	Excellent	Excellent	Excellent
Resistance - Water Absorption	Good	Good	Good	Good	Excellent
Resistance - Oxidation	Good	Good	Good	Excellent	Excellent
Resistance - Ozone	Poor	Poor	Poor	Excellent	Excellent
Resistance - H2S	Poor	Poor	Fair	Fair	Good
Resistance - CO2	Poor	Poor	Fair	Fair	Good
Resistance - Sunlight Aging	Poor	Poor	Good	Excellent	Excellent
Resistance - Heat Aging	Fair	Good	Excellent	Excellent	Excellent
Resistance - Low Temperature	Good	Fair	Good	Good	Fair
Resistance - Flame	Poor	Poor	Good	Good	Excellent
Resistance - Chlorinated Hydrocarbons	Poor	Fair	Poor	Good	Good - Excellent

ELASTOMER RECOMMENDED OPERATING TEMPERATURE

Elastomer Material	Recommended Operating Range			
	Low Temperature		High Temperature	
	°C	°F	°C	°F
Natural (NR)	4	40	82	180
Carboxylated Nitrile Rubber (XNBR)	4	40	82	180
Nitrile Rubber (NBR)	4	40	82	180
Hydrogenated Nitrile Butadiene Rubber (HNBR)	4	40	107	225

TEMPERATURE RATING FOR NON-METALLIC SEALING MATERIAL

Code	Lower Limit		Code	Upper Limit	
	Temperature			Temperature	
	°C	°F		°C	°F
A	-26	-15	A	82	180
B	-18	0	B	93	200
C	-12	10	C	104	220
D	-7	20	D	121	250
E	-1	30	E	149	300
F	4	40	F	177	350
G	Other	Other	G	Other	Other
X	See note	See note	X	See note	See note

*NOTE: These components may carry a temperature class 4 °C to 82 °C (40 °F to 180 °F) without performing temperature verification testing provided they are marked as temperature class "XX".

**Example: Material "EB" has a temperature rating of -1 °C to 93 °C (30 °F to 200 °F).

As per API 16A (Table 4)

INTEGRATED OEM MANUFACTURED

STORAGE AND AGE CONTROL GUIDELINES

The following outlines the proper storage of elastomeric products to achieve maximum acceptable condition and their storage shelf life as defined in Table A & B. ISO 2230:2002 provides guidelines for the storage and for determining the shelf life of vulcanized rubber products.

TEMPERATURE:

- The optimum temperature for the storage of rubber products is between 50°F (10°C) and 80°F (27°C). Higher temperatures cause a gradual hardening of the rubber and accelerate the deterioration of rubber products, so sources of heat in storage rooms should be arranged such that the temperature of stored items never exceeds 100°F (38°C).
- Elastomers parts undergo several kinds of change when they are exposed to low temperatures. In temperatures of -20°F (-20°C), the rubber becomes brittle and will shatter when dropped or handled roughly. Some changes occur immediately, others after prolonged exposure. All are reversible; the rubber regains its original properties when it is returned to 65°F (18°C) or room temperature.

HUMIDITY:

- All elastomer products shall be stored in moisture proof bags, if not the relative humidity level shall be less than 65%. Condensation should not be allowed to occur.

LIGHT:

- All elastomeric products must be protected from Ultraviolet radiation (either indoor lighting and/or sunlight). Polyethylene (PE) bags stored in large cardboard containers and polyethylene lined craft bags offer good protection against light. Integrated elastomer recommends 4 mil minimum thickness, opaque, polyethylene plastic wrap and/or sealed as far as practical.

OZONE (O3) AND OXYGEN (O2):

- Integrated parts must be stored in airtight containers to protect them from circulating air. Or else this will cause cracks, which can be formed in many different elastomers (Natural rubber, polybutadiene, Styrene-butadiene rubber and NBR) by ozone attack and causes a breaking of the carbon backbone polymer chain into smaller chains. This weakens the rubber by lowering its molecular weight, and cracks start to grow in the regions affected.

DEFORMATION:

- All elastomeric products should be stored in a relaxed state, free from tension, compression, or other deformation since these may lead to cracking or change of shape. Packing element should not be stored on pegs as this may cause severe deterioration.

EXPOSURE TO CHEMICALS:

- Chemical degradation can change polymers properties due to a chemical reaction such as breaking its double bonds (rubber more brittle followed by crack) or swelling of rubber. This can reduce product's overall functional life. So, all elastomer products shall not come in contact with any chemicals unless these materials are by design an integral part of the component or Integrated Elastomer's packaging.

STRUCTURAL DAMAGE TO PRODUCT:

- Permanent deformations (folds, wrinkles or flattening areas)
- Mechanical damage (cuts, cracks, worn or dissolved areas)
- Changes to the surface (stiffening, softness, stickiness, discoloration or dirtiness)

The variations in size, composition and function of the rubber parts prevent defining a precise shelf life. Large rubber parts might suffer the same amount of deterioration as small parts and still be usable, whereas small parts become useless and should be thrown away. Both Natural and Synthetic rubber parts are susceptible to deterioration from various solvents such as oilfield liquid hydrocarbons, which causes swelling or shrinkage. In the final analysis, ownership judgement determines whether a rubber part should be used. If there is doubt, replace the part.

TABLE A

STORAGE CONDITIONS FOR RUBBER AND ELASTOMERIC PRODUCTS

Storage Parameter	Recommended Storage	Minimum Acceptable	Unacceptable Storage
Temperature	Less than 80°F (27°C)	Less than 120°F (49°C)	Greater than 120°F (49°C)
Light	Complete Darkness	Indirect Light	Direct Light
Stress	Separate Packages	Sacks of Loose Parts	Pinched, Stretched, Creased
Environment	Clean Dry Air	Humid Air	Oil, Grease and / or Water
Oxygen and Ozone	Sealed Package	Open Air	Near Electric Motors / Arcs

TABLE B

RUBBER AND ELASTOMERIC PRODUCTS STORAGE LIFE LIMITS

Type of Components	Type of Elastomer	Maximum Total Storage Life
Annular BOP Packing Elements	Nitrile (NBR)	6 Years
Annular BOP Packing Elements	Natural Rubber (NR)	6 Years
Annular BOP Packing Elements	Hydrogenated Nitrile (HSN & XHSN)	7 Years
BOP Ram Block Elements	Nitrile (NBR and XNBR)	6 Years
BOP Ram Block Elements	Hydrogenated Nitrile (HSN & XHSN)	7 Years
Annular BOP Square Seals, Lip Seals, Headers	Nitrile (NBR)	5 Years
Annular BOP O-Ring Cross Sections	Nitrile (NBR)	5 Years
BOP Ram Block Top and Lateral Seals	Nitrile (NBR and XNBR)	5 Years
BOP Ram Block Top and Lateral Seals	Hydrogenated Nitrile (HSN & XHSN)	6 Years
Ram BOP Bonnet Seals	Nitrile (NBR and XNBR)	5 Years
Ram BOP Bonnet Seals	Hydrogenated Nitrile (HSN & XHSN)	6 Years
Polypack, Wipers, etc.	Polyurethanes and combinations with Nitriles (NBR, HSN and U)	6 Years
Drill Stem Valve Seals (Packing and Molded Lip Seals)	Nitrile (NBR)	6 Years
Pulsation Dampeners, PD	Fluoropolymers (FKM)	10 Years
Pulsation Dampeners, PD	Other Elastomeric Materials	6 Years
Pipe Wipers	Natural Rubber (NR)	5 Years
Seal Kits, Annular & Ram BOPs	Nitrile (NBR)	5 Years
Stripper Rubbers & Red Wipers	Natural Rubber (NR) and Neoprene (CR)	5 Years
Bladders & Diaphragms	Natural Rubber (NR)	5 Years
Bladders & Diaphragms	Hydrogenated Nitrile (HSN)	6 Years

Maximum Total Storage life specified in Table B is applicable only if minimum acceptable storage conditions are maintained as per Table A.

REFERENCED DOCUMENTS

API 6A – 20TH Edition | API 16A – 4TH Edition | ISO 2230:2002

ELASTOMER PACKAGING CODE SYSTEM (as per API 16A Edition 4)

Example of Product Code on Elastomer Packing: AA BBBB CCCC DDDD EEE FFF

Table 42 (API 16A Edition 4) – Code System for Non-Metallic Sealing Materials

CODE	DESCRIPTION
AA	Compound hardness (durometer)
BBBB	Elastomer Compound Marking Code (see Table 43 and ASTM D 1418)
CCCC	Date of manufacture (see 8.4.2.5)
DDDD	Lot / Serial number (in accordance with manufacturer’s specifications)
EEE	Temperature class (see Table 4)
FFF	Date of expiration

INTEGRATED**GENERAL TERMS AND CONDITIONS**

All INTEGRATED (Integrated Equipment, Integrated Elastomers, Integrated Tubular Solutions and "INTEGRATED") products and services are sold, leased or otherwise furnished in accordance with these General Terms and Conditions. These Terms and Conditions supersede all prior terms and conditions and shall be the sole terms and conditions which apply to any sale, lease or other furnishing of products or services. Acceptance by Buyer, lessee or user (hereinafter collectively referred to as "Buyer") of the products and/or services provided by Seller pursuant to any order or request from Buyer shall be deemed a full acceptance by Buyer of all of the Terms and Conditions set forth herein. Different or additional terms proposed by Buyer are deemed material alterations and are objected to and rejected unless agreed to by INTEGRATED in writing. INTEGRATED is referred to as "Seller" in these General Terms and Conditions.

1. (a) Subject to the limitations hereafter set forth, Seller warrants the products and services sold by it to be free from defects in workmanship or material for one year from (I) shipment from Seller's date of shipment in the case of products or (II) the completion of performance of services in the case of services. Seller's obligation under this warranty for any products or services found by Seller to be defective in workmanship or material is limited to, at Seller's option, repairing or replacing such products, or performing such services, or refunding the amount which Seller received from Buyer for such products or services. In no event shall Seller be liable for special, indirect, incidental or consequential damages including environmental damage or remediation claims, WHETHER OR NOT CAUSED BY THE NEGLIGENCE OR FAULT OF SELLER. It is expressly agreed that THIS WARRANTY SHALL BE IN LIEU OF ANY OTHER WARRANTY, EXPRESSED OR IMPLIED, INCLUDING ANY IMPLIED WARRANTY OF MERCHANTABILITY OR FITNESS FOR ANY PARTICULAR PURPOSE, WHICH ARE HEREBY EXPRESSLY DISCLAIMED. To the full extent allowed by law, Seller disclaims any warranty to any persons other than Buyer.

(b) In addition, this warranty shall not apply if the product or service has been subject to misuse, negligence or accident, modification, heating, machining, bending, welding, or alteration of any kind, or has not been operated or installed in accordance with Seller's instructions or has been operated under conditions more severe than, or otherwise exceeding, those set forth in the specifications for the product or service. This warranty does not extend to Seller products used with components which are not manufactured or approved by Seller.

(c) Seller does not warrant that its products or services meet the requirements of any safety code of any state, municipality or other jurisdiction or that they will perform as anticipated or desired by Buyer and Buyer assumes all risk and liability whatsoever resulting from the use thereof, whether used singly or in combination with other machines, apparatus, or equipment.

(d) Products furnished by Seller but not manufactured by Seller will carry only the warranty of the manufacturer of such products, if any. Seller does not warrant any products not manufactured by Seller.

(e) Products and services shall be subject to Seller's stated manufacture variations. All tables published by Seller are based upon information believed reliable; however, Seller does not guarantee accuracy of same. All measurements and weights set forth in such tables are subject to reasonable tolerance variations.

(f) Any claim on account of defective materials or services, shall conclusively be deemed waived by Buyer, lessee or user unless (I) Seller is promptly given notice in writing of any such defect during the warranty period set forth in (a) above; (II) Buyer has kept such products or results of services in condition so that Seller can examine same. Unless otherwise agreed, Buyer shall at its expense return any product claimed to be defective to Seller's plant of manufacture. If Seller confirms the product to be defective, Seller will reimburse Buyer for transportation costs and provide Buyer with a repaired or replacement product ex works Seller's plant of manufacture at no cost to Buyer.

(g) In the event of a warranty claim, all parts to the capital equipment in question, shall be Integrated Equipment, Inc. brand, original equipment manufactured goods; including, but not limited to rubber seals, packers and elements. Any unauthorized modifications to original parts or replacement goods installed in or on the capital equipment in question shall void any stated or implied warranty and any and all repair work shall be charged at current facility rates including freight.

(h) The liability of Seller for any loss or damage in any way resulting to Buyer or any other person from any failure of a product or service to conform to order or specification, or on account of breach of warranty, or NEGLIGENCE or failure to conform to any standard of care in anything done or omitted by Seller or any employee or agent, or on account of patent infringement, shall not in any event exceed the amount which Seller received from Buyer for the product or service found to be defective. Where other manufacturers' or suppliers' products used in Seller products prove defective, Seller's liability shall exist only to the extent that Seller is able to recover from such manufacturers or suppliers for said defects. The foregoing applies whether or not such damage was caused by the negligence or fault of Seller.

(i) Seller's liability for damage to or loss of property of Buyer or others during performance of work thereon by Seller or while in Seller's possession shall not exceed the price received by Seller for its work on the article lost or damaged whether or not such damage was caused by the negligence or fault of Seller.

2. Seller retains the right to make substitutions and modifications to its product or services, provided that said changes do not affect the performance of those items.

3. Seller retains the ownership of all proprietary rights in and to all designs, engineering details and data concerning the services or products sold by it.

4. Any taxes or charges which Seller may be required to pay or collect under any existing or future law upon or applicable to the sale, purchase, lease, furnishing, manufacture, processing, transportation, delivery, storage, use or consumption of the product or services shall be for the account of Buyer and Buyer shall reimburse Seller upon receipt of Seller's invoice.

5. Failure of Seller to enforce any of these conditions or to exercise any right arising from the default of Buyer shall not affect or impair Seller's rights in case such default continues or in the event of any subsequent fault of Buyer nor shall failure constitute a waiver of any of these conditions.

6. (a) Seller shall make delivery of all products EX WORKS (Unpacked) at Seller's designated facility. Seller will use its best efforts in good faith to deliver the goods on or before the agreed delivery date, as adjusted in accordance with the terms hereof. Products stored at the request of the Buyer shall be so stored at the risk of Buyer. Buyer shall pay Seller reasonable storage charges, and shall reimburse Seller for any additional sales and/or use tax liability caused by such storage.

(b) Seller is not liable for delays in delivery or failure to make delivery caused by the elements, acts of God, lack of or inability to obtain materials, fuel or supplies, acts of Buyer, acts of civil or military authorities, breakdown of equipment, differences with workmen, fire, flood, or other casualty, labor shortages, governmental regulations or requirements, orders bearing priority rating established pursuant to law, shortages or failure of raw materials, supplies, fuel, power or transportation, or other causes beyond the reasonable control of Seller, whether similar or dissimilar to those enumerated, and whether or not foreseeable, and any delivery date will be extended accordingly.

(c) Seller shall maintain a purchase money security interest in the products for any portion of the purchase price not paid at the time of delivery and shall retain this interest until Buyer has paid the full purchase price. Buyer agrees to execute any documents required by Seller to perfect its security interest.

INTEGRATED**GENERAL TERMS AND CONDITIONS**

7. Subject to the limitations set forth in Paragraph 1 above and in this Paragraph 7, Seller shall indemnify and hold harmless Buyer from and against all claims, suits, actions, and costs for patent infringement (excluding any consequential damages, liabilities, costs, and loss of revenue or profit resulting from loss of use of the product, but including costs of replacing the infringing product or otherwise curing the infringement), provided that:

(a) Buyer shall give Seller prompt written notice of any suit for or claim of infringement

(b) Seller's liability under this indemnity shall not exceed the amount received by Seller from Buyer for such product. This indemnity shall not apply to any product not manufactured by Seller or to any product made, in whole or in part, to Buyer's specifications, and also shall not apply to the use of a product in combination with other materials in such a manner that the combination (and not the product manufactured by Seller) is the basis for the claim of infringement. Seller shall be entitled, at its option, to settle or compromise any claim or suit for infringement and to intervene in and/or to control the defense of any infringement suit. The Indemnity in this Paragraph 7 is in lieu of any other warranty or indemnity, express or implied, with respect to infringement.

8. The partial invalidity of any of these Terms and Conditions arising by operation of law shall not affect the validity and applicability of the remainder thereof. Seller may assign its rights under this order to any entity that is controlled by Seller, controls Seller, or is under common control with Seller.

9. No statement or recommendation made or assistance given by Seller or its representatives to Buyer or its representatives shall constitute a warranty by Seller or a waiver or modification of any of the provisions hereof or create any liability for Seller. There are no understandings or agreements between Buyer and Seller relative hereto which are not fully expressed herein. These General Terms and Conditions contain the entire agreement of the parties regarding the subject matter hereof.

10. With respect to any tubular goods acquired from Seller by Buyer, Buyer agrees to handle such goods in accordance with API Publication RP 5C1, Care and Use of Casing and Tubing, including without limitation section 6.3 thereof, Storage, and with good industry practice, and to defend, indemnify and hold harmless Seller from any loss, cost or damage resulting from Buyer's failure to perform its obligations under this section ten (10).

11. RETURN GOODS POLICY:**Authorization:**

All Integrated returns must be processed through the Integrated Returns Department. All returns must be accompanied by a return authorization number. Any returns made IEL/WSI without approval will not be accepted and will be returned to the sender at their expense.

Policy (For Sales through Stock Inventory):

Seventy-Five percent (75%) of the original invoice value (excluding shipping) will be credited on all Integrated products that are returned, in unused, as new condition within 2 months of the invoice date. Merchandise sold to Distributors is considered a final sale and no returns will be accepted or credit issued. Commissions or other fees to agents and distributors will not be paid on returned goods. This policy does not affect or alter our warranty policy.

Policy (For Production Orders)

Integrated holds the right to reject cancellations for production orders.

12. Unless otherwise agreed, Seller's payment terms are net thirty (30) days from invoice date.

13. Buyer agrees to transmit a copy of the Terms and Conditions set forth herein to any and all persons to whom Buyer sells, leases or otherwise furnishes the products and/or services provided Buyer by Seller and to obtain such person's agreement thereto, and Buyer agrees to defend and indemnify Seller for any liability, loss, costs and attorneys' fees which Seller may incur by reason, in whole or part, of failure by Buyer to transmit the Terms and Conditions as provided herein, whether or not such damage was caused in whole or in part by the negligence or fault of Seller.

14. These General Terms and Conditions and any Special Conditions which may apply shall be construed under and governed by the laws of the State of Texas, U.S.A., excluding any conflict of laws principles which would call for the application of the law of another jurisdiction. To the extent the laws of any other jurisdiction are held to apply, Buyer hereby waives to the full extent permitted under such laws all rights given Buyer under such laws which are not also afforded by the laws of the State of Texas.

15. Buyer agrees to and shall defend, indemnify and hold harmless Seller Group from and against any and all claims, losses, damages, causes of action, suits, judgments, contractual indemnity obligations and liability of every kind, including all expenses of litigation, court costs, and reasonable attorney's fees, for or by reason of any injury to or death of any person or persons employed by Buyer or its suppliers and/or subcontractors, or for damage to any property owned or rented by Buyer (other than the Goods being purchased under this Purchase Order prior to delivery to Buyer) or any of its suppliers and/or subcontractors regardless of the cause of such injury, death or damage. Seller accepts the same responsibility towards Buyer Group for injury or death to employees of Seller and its other contractors and damage to property of Seller or its other contractors regardless of the cause of such injury, death or damage. In the event of claims for injury or death to any person or persons or damage to property owned by any person or persons not covered in the preceding two sentences, each party shall defend, indemnify, and hold the other party harmless in the proportion that the indemnifying party's negligence, fault or omission caused or contributed to the alleged injury, death or damage. If for any reason this indemnity provision violates public policy, it shall be enforceable to the extent that these indemnity and hold harmless obligations are limited to the Seller's insurance or self-insurance coverage, which Seller shall obtain to cover its obligation herein and which does not exceed the amount of insurance coverage allowed by law. Without limitation, "any person or persons" shall include purchasers or users of the items ordered herein. "Buyer Group" and "Seller Group" mean Buyer or Seller, respectively, and its parent company, all subsidiaries and affiliates, and its and their officers, directors, employees, agents, insurers, licensors, shareholders and invitees.

16. Buyer acknowledges that these General Terms and Conditions include provisions for the indemnification and/or exoneration of Seller against the consequences of its own negligence or fault, and agrees that these General Terms and Conditions comply with the express negligence rule, are conspicuous and afford fair notice.

17. Force Majeure. Seller shall not be in default or liable to the Buyer for any costs on account of any failure to perform or for any delay in making deliveries hereunder if the same are attributable to a Force Majeure condition. In all cases involving a Force Majeure condition this Order shall continue in effect and shall be unaffected thereby (except for delivery dates). As used herein, the term "Force Majeure" shall mean all acts and events beyond the reasonable control of Seller or any of its suppliers or contractors including, but not limited to acts of God, acts of the public enemy, insurrections, riots, civil disturbances, strikes, boycotts and other direct consequences of a labor dispute or an industrial disturbance, fires, explosions, floods, severe weather conditions, breakdowns of or damage to machinery, tools, equipment or production facilities, freight embargoes, power or utility failures, laws, rules, regulations, ordinances, restraining orders and preliminary injunctions, shortages of or the inability to contract for or obtain equipment, materials, supplies or transportation facilities, and any orders, acts or other similar causes beyond the reasonable control of Seller.

INTEGRATED
INTEGRATED CORPORATE STATEMENTS
INTEGRATED QUALITY POLICY

Integrated maintains an organizational culture, commitment, and determination to achieve excellence in quality and complete customer satisfaction by delivering defect-free products and unmatched service on time every time through continual improvement in all processes.

INTEGRATED MISSION STATEMENT

To support our customers by providing superior products and services of exceptional value which help them gain competitive advantage in their markets. To sustain our mission and vision by constantly seeking renewal via continuous education and learning and the application of new technologies and best business practices. To provide a pleasant, nurturing and growth oriented environment which encourages our employees to be highly productive and to grow personally and professionally. To develop diversified markets which provide stability and adequate financial returns which allow us to achieve our vision and to provide opportunity for Integrated employees that follow us.



INTEGRATED CODE OF CONDUCT

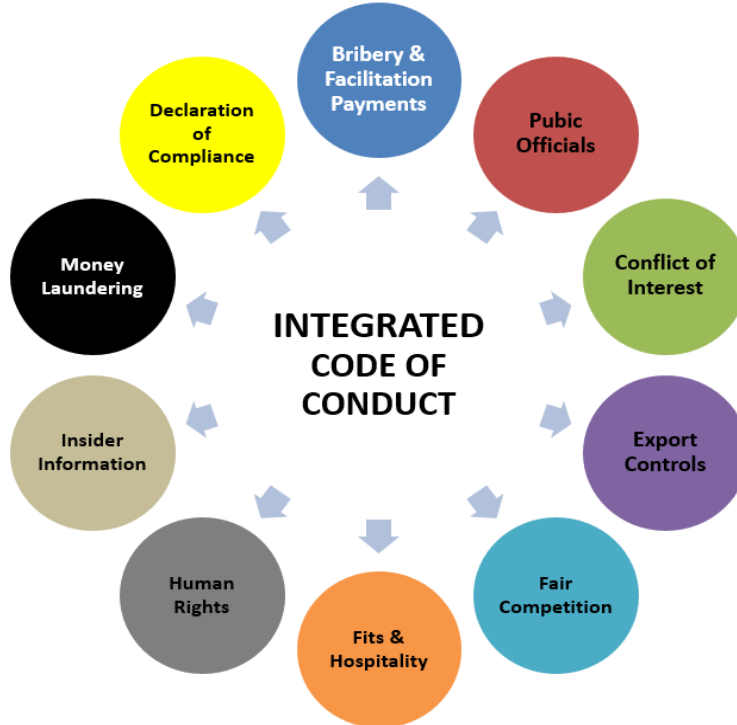

The Code of Conduct outlines Integrated ethical commitments and requirements and sets expectations for personal conduct and business practices.

Integrated shall conduct its business with integrity, respecting the laws, cultures, dignity and rights of individuals in all the countries where we operate. All Integrated employees are expected to live by our values.

Together with Integrated values, this Code of Conduct constitutes the basis and framework for our performance culture and governing documents. Integrated governing documents consist of policies with associated standards and tools, that in some instances will address the below issues in more detail, but also addressing important issues that are complementary to the business integrity matters subject to this Code of Conduct.

HEALTH, SAFETY, SECURITY AND ENVIRONMENT

Integrated provides a healthy, safe and sustainable place to work and we know that creating such a work environment produces better business outcomes. We partner with our customers to ensure our products and work sites meet global environmental and safety requirements. We are accountable for our own safety and the safety of others at the workplace. All Integrated employees are vigilant to security concerns when they travel; health and safety risks when we plan project deployments; and environmental consideration when we design and build products.

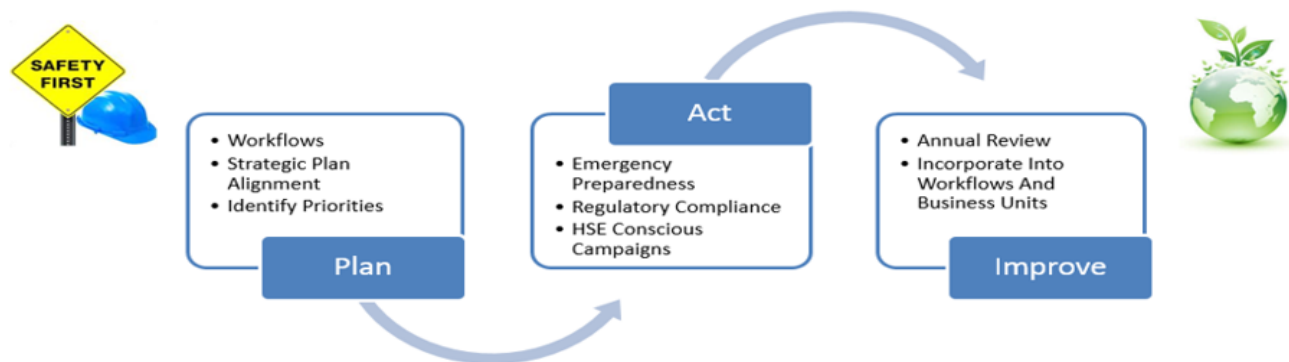

HSE POLICY INCLUDES CLEAR GOALS FOR ALL OUR OPERATIONS

- Expect 100% Compliance in all places Integrated operates or sells products
- Provide Safe and Environmentally friendly work place
- Minimize the Use and Release of hazardous materials
- Asses all new activities and products for Environment, Health and Safety impacts
- Implement the HSE Management System in all locations



GLOBAL DISTRIBUTION OF INTEGRATED MANUFACTURED PRESSURE CONTROL EQUIPMENT & ELASTOMERS
USA | Canada | Mexico | Colombia | Dubai | Singapore | Australia | Bahrain

INTEGRATED®

GLOBAL HEADQUARTERS

5701 Brittmoore Road, Houston, Texas 77041 USA

Contact: 713-785-7075 | Fax: 713-785-7099 | Email: sales@integratedwww.com | Website: integratedwww.com

INTEGRATED ELASTOMERS® USA

OEM ELASTOMER MANUFACTURING PLANT

31811 Industrial Park Drive, Pinehurst, Texas 77362 USA

INTEGRATED EQUIPMENT® WEST TEXAS USA

DISTRIBUTION FACILITY

13020 Hwy 191 – Suite H, Midland, Texas 79707 USA

INTEGRATED EQUIPMENT® LIMITED

OEM EQUIPMENT MANUFACTURING PLANT

Pune-Nagar Highway, Kondhapuri, Pune 412209

- ❖ **Australia ARLF** (Authorized Repair License Facility) & Distribution
Well Control Solutions (WCS)
24 Enterprise Street, Richlands, QLD 4077
Contact: +61-7-3375-4388 | Email: sales@well-control.com.au



- ❖ **Canada ARLF** (Authorized Repair License Facility) & Distribution
Red Deer Well Control (RDWC)
6670 – 53rd Avenue, Unit #B, Edmonton, Alberta T6B 3H8
Contact: +780-466-3149 | Email: aspalding@rdwc.com

